

TWIN XL

ASSEMBLY INSTRUCTIONS

Before assembling your Murphy bed, please read through these instructions carefully and familiarize yourself with the different parts.

ATTENTION! If you receive a damaged or defective item, please contact afifurnishings at customerservice@afifurnishings.com or 1-800-955-3726

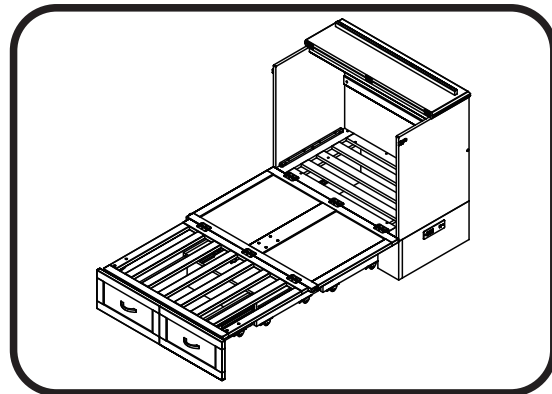
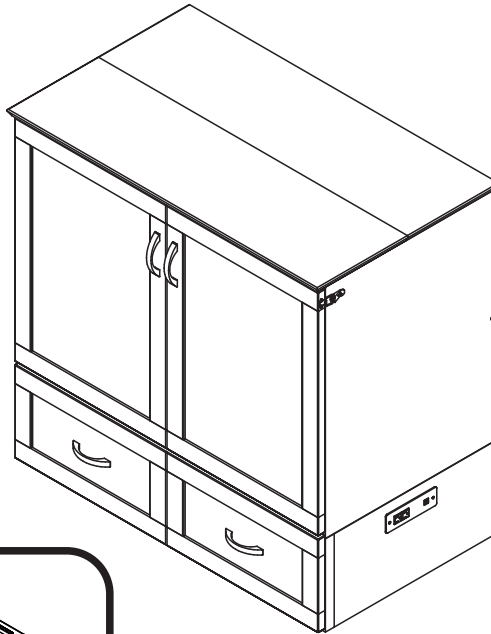

CODE	ITEM
MB-CB-HML	C-6213X
MB-DB-HML	C-6214X

PO : _____

HARDWARE

NOTE: WE INCLUDE SPARE HARDWARE IN CASE DAMAGE OCCURS DURING ASSEMBLY.

- A** Wood dowel - 10 pcs
Spare - 1 pc
- B** JCB M6 X 25mm - 10 pcs
Spare - 1 pc
- C** Wood screw 5/8" - 9 pcs
Spare - 1 pc
- D** JCB M6 X 60mm - 2 pcs
Spare - 1 pc
- E** Barrel Nut - 2 pcs
Spare - 1 pc
- F** Metal pull - 4 pcs
- G** Metal pull screw 25mm - 8 pcs
Spare - 1 pc
- H** Washer - 24pcs
Spare - 1 pc
Adjust quantity as needed.
- I** Triangle Bracket - 2 pcs
- J** Wood screw 1" - 8 pcs
Spare - 1 pc
- K** Allen wrench - 1 pc
Spare - 1 pc

TWIN XL

PARTS LIST

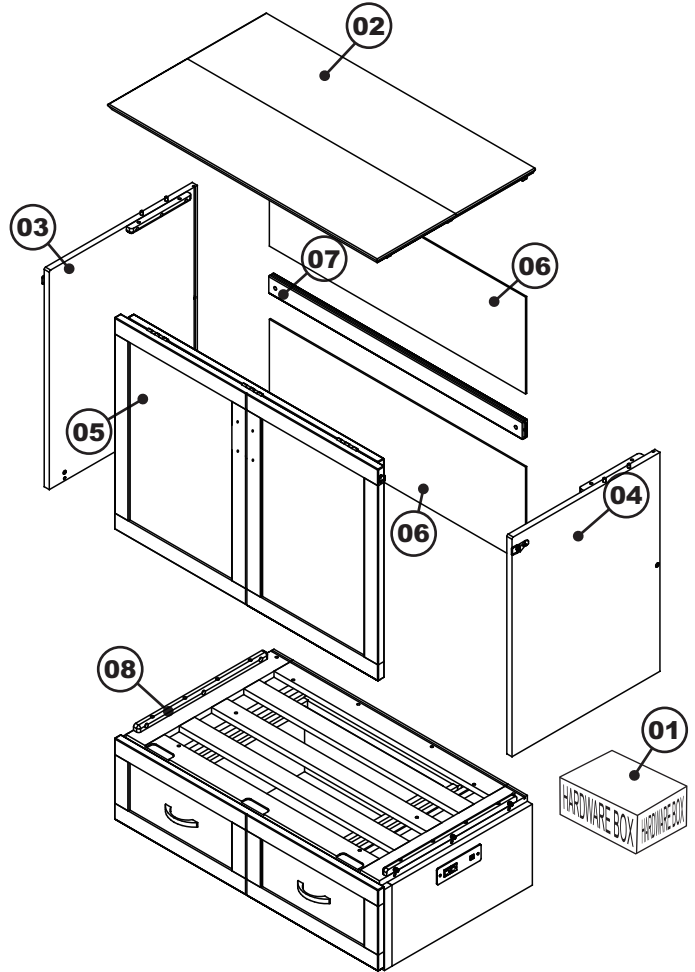
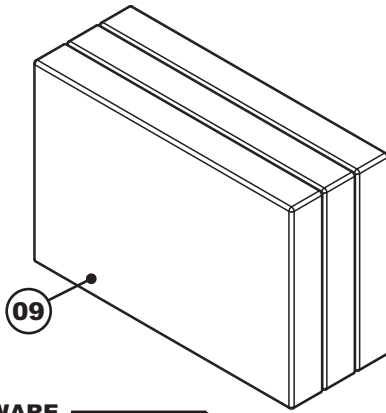

- 01 HARDWARE
 - 02 TOP PANEL
 - 03 LEFT SIDE PANEL
 - 04 RIGHT SIDE PANEL
 - 05 DOOR
 - 06 BACK PANEL
 - 07 MIDDLE BACK RAIL
 - 08 DRAWER BASE
 - 09 FOLDING MATTRESS
- 1 BOX
- 1 BOX
- 1 BOX

STEP 1

Insert all wooden dowels (A) into the locator holes on (03)(04) and (08) as shown below.

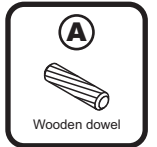
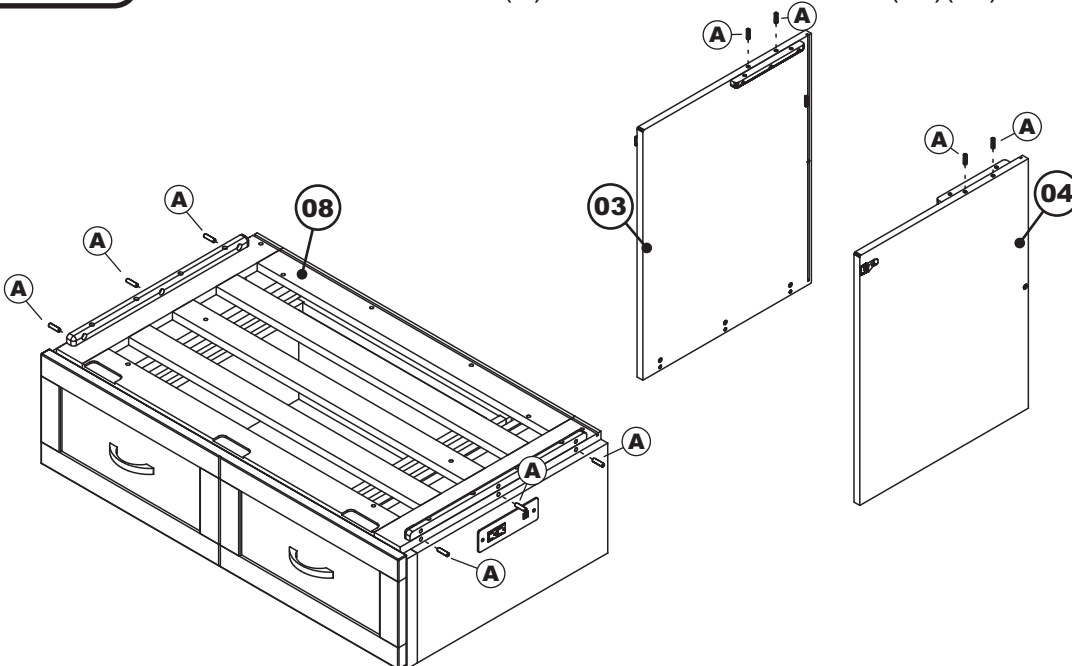

TWIN XL

STEP 2

Attach left and right side panels (03) and (04) to the drawer base (08) as shown below. Using JCB (B) tighten with Allen wrench (K)

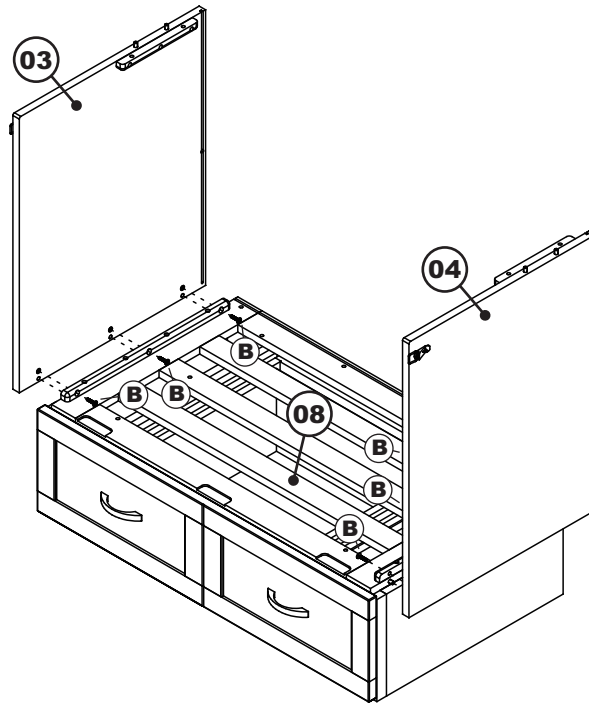

STEP 3

Guide the back panel (06) in carefully so that it won't jump out of its grooves. Be sure it fits fully into its groove at the top panel base.

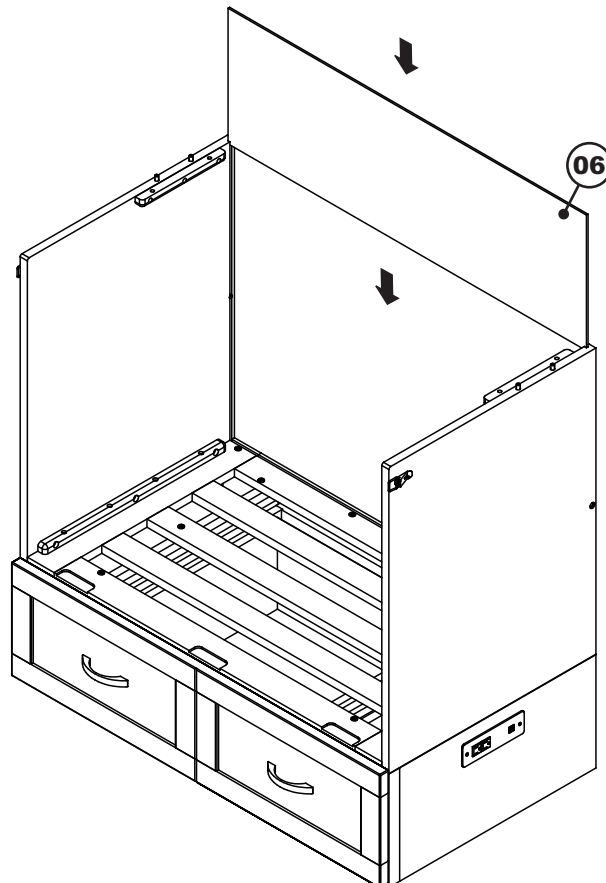

TWIN XL

STEP 4

Guide the middle back rail (07) in carefully so that it won't jump out of its grooves. Using JCB (D) and barrel nut (E). Tighten with Allen wrench (K).

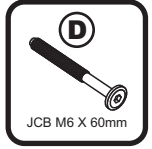
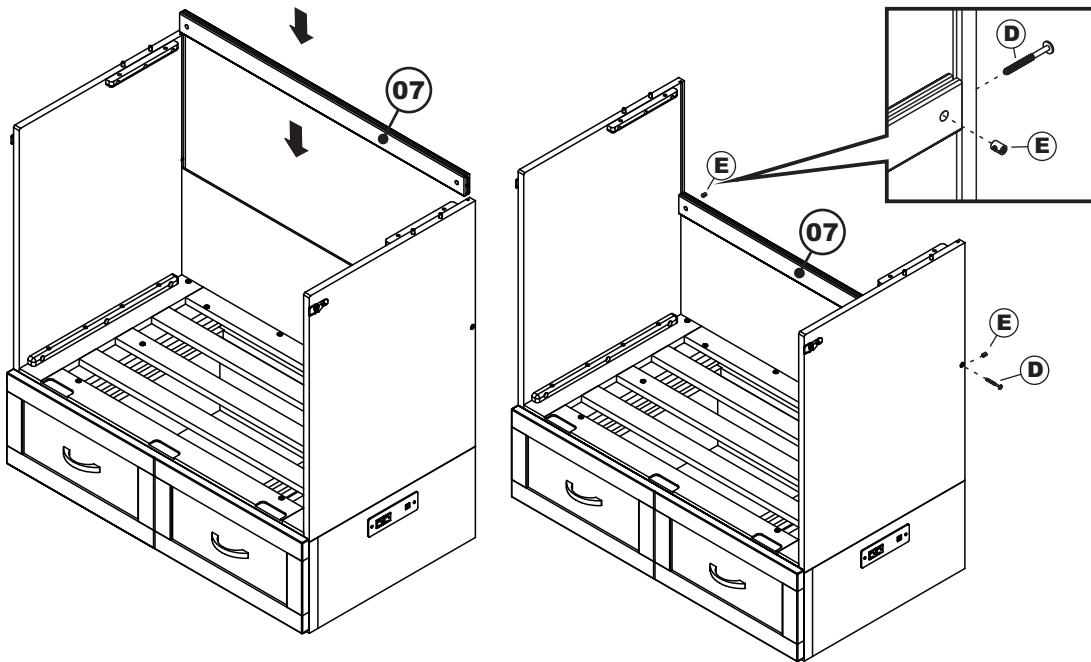

STEP 5

Guide the back panel (06) in carefully so that it won't jump out of its grooves. Be sure it fits fully into its groove at the middle back rail. Attach top panel (02) to cabinet assembly as shown below. Use JCB (B). Tighten with Allen wrench (K).

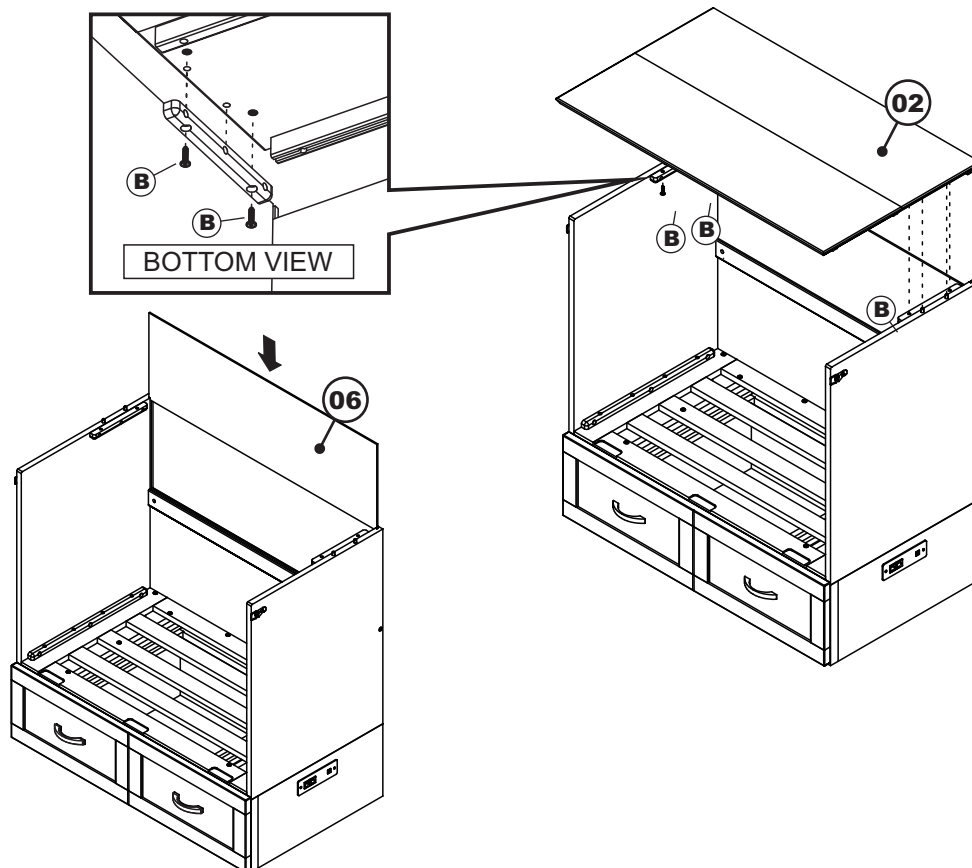

TWIN XL

STEP 6

Install metal pull (F) to the locator holes on (05) as shown below. Using metal pull screw (G) and washers (H) tighten with Phillips screwdriver (customer supplied).

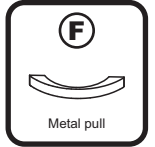
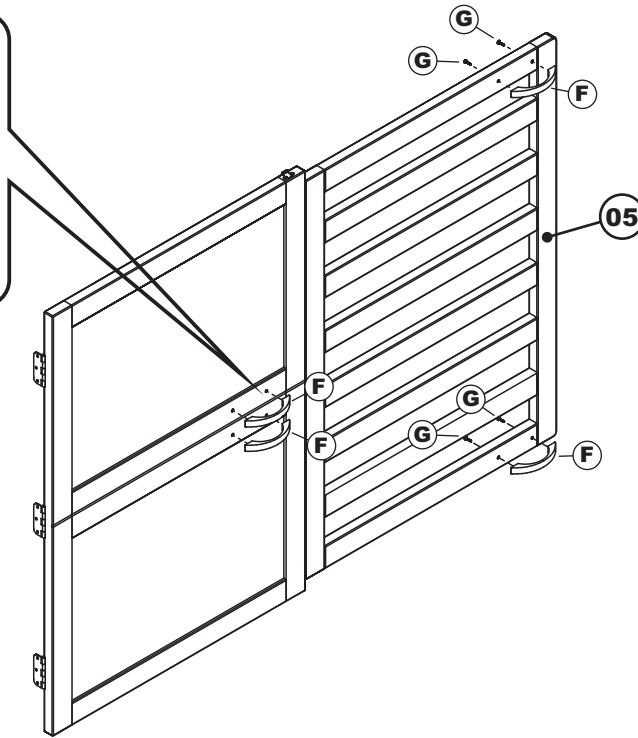
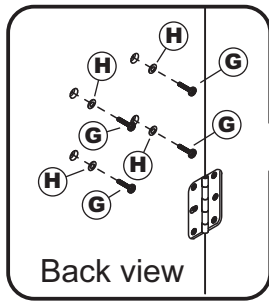

STEP 7

Lay the door down flat as shown below. Attach door hinge to drawer base using wood screw (C) and tighten with Phillips screwdriver (customer supplied).
Note: Be sure to align door with side panels in this step.

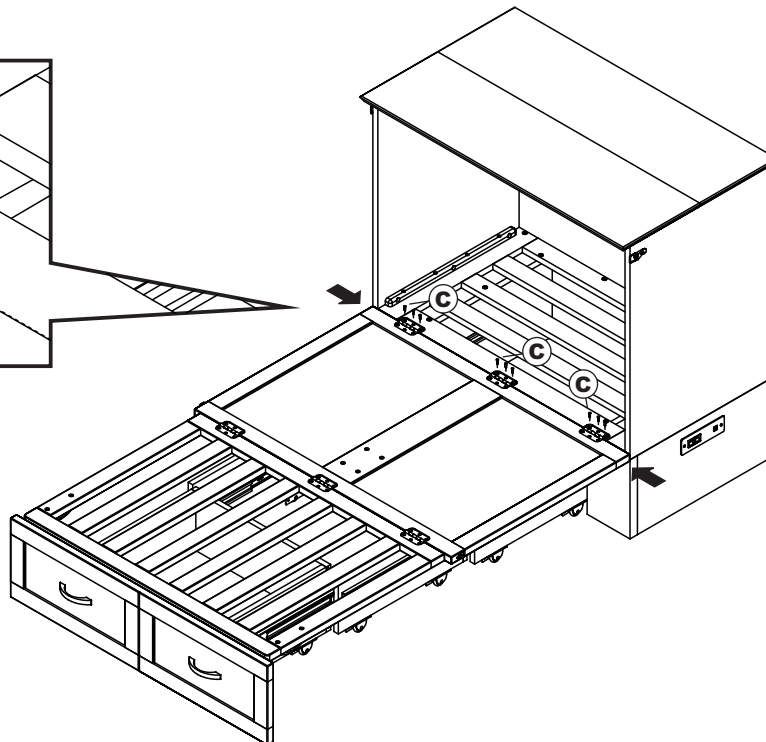
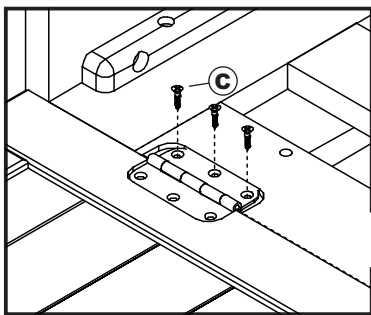

TWIN XL

STEP 8

① Lift the door and fold as shown below.

② Lift the door and latch to side panel as shown below.

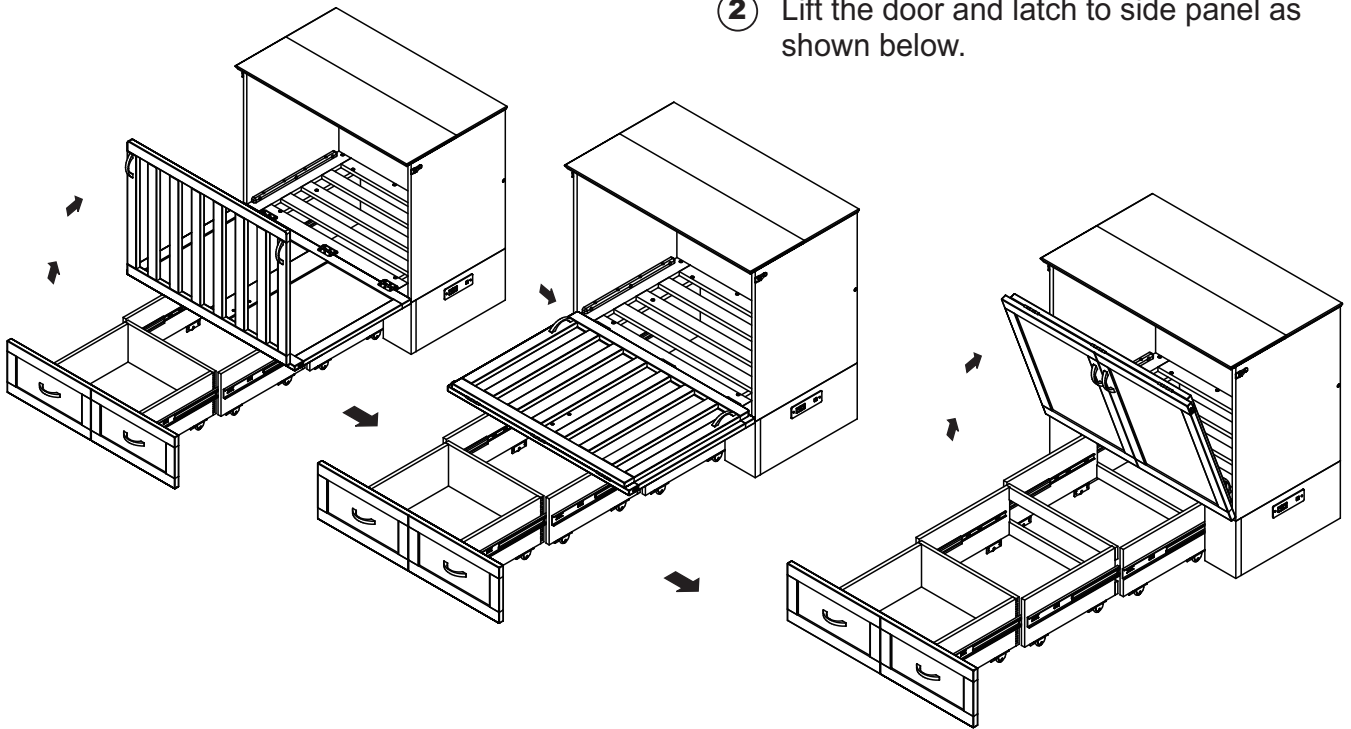

STEP 9

Push the door closed and latch both sides as shown below.

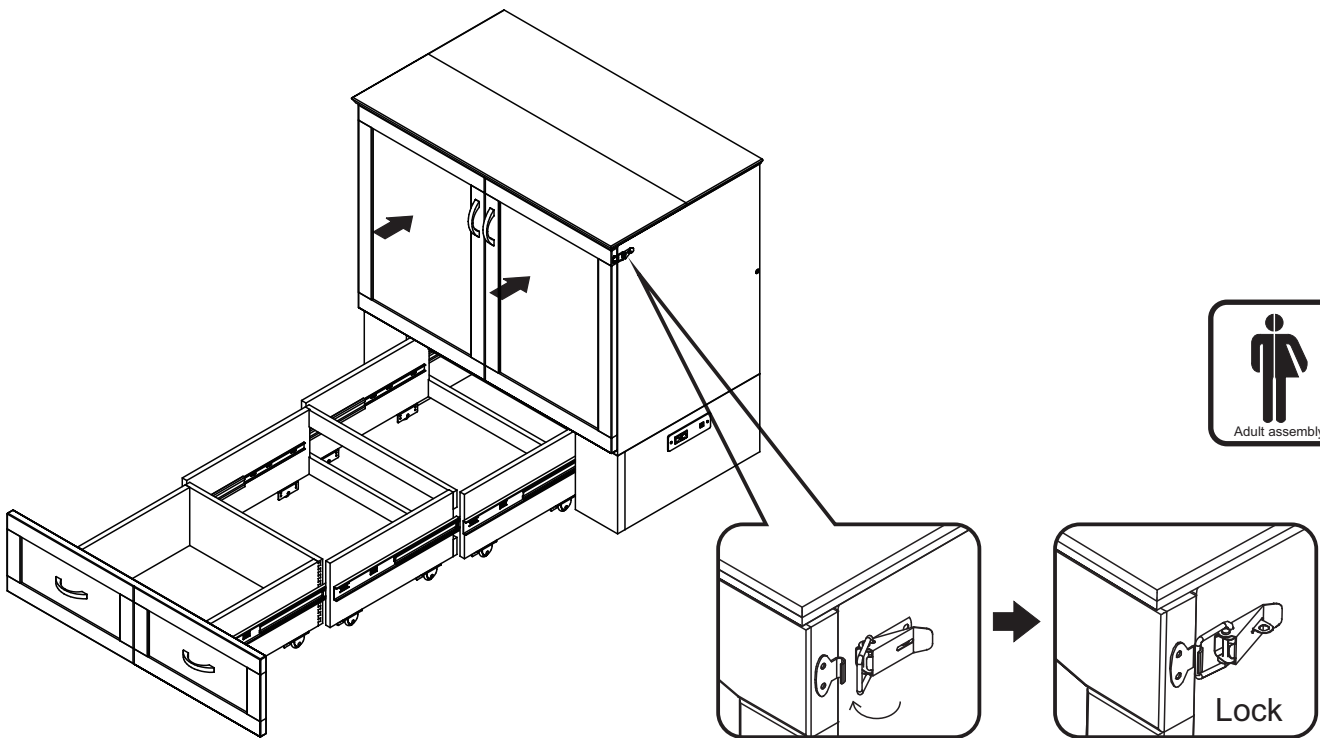

TWIN XL

STEP 10

Attach triangle bracket (I) to the back of cabinet as shown below. Use wood screw (J) tighten with Phillips head screwdriver. (customer supplied).

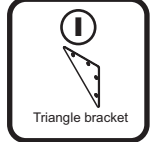
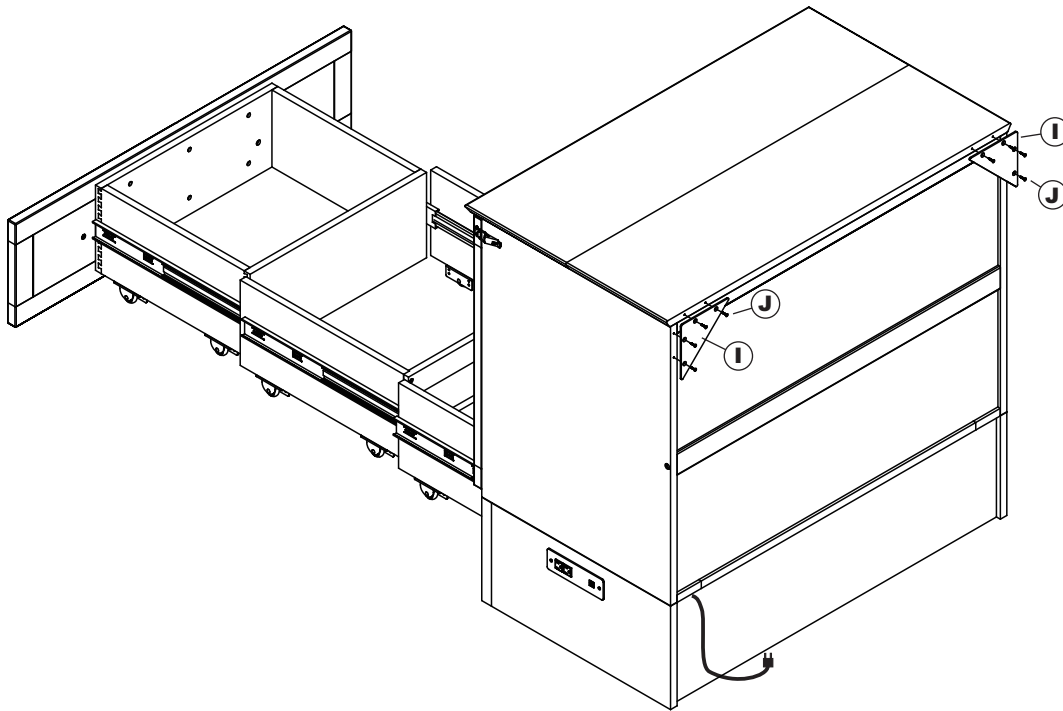

STEP 11

Pull the drawer out fully. Unlatch the door and open, folding down as shown.

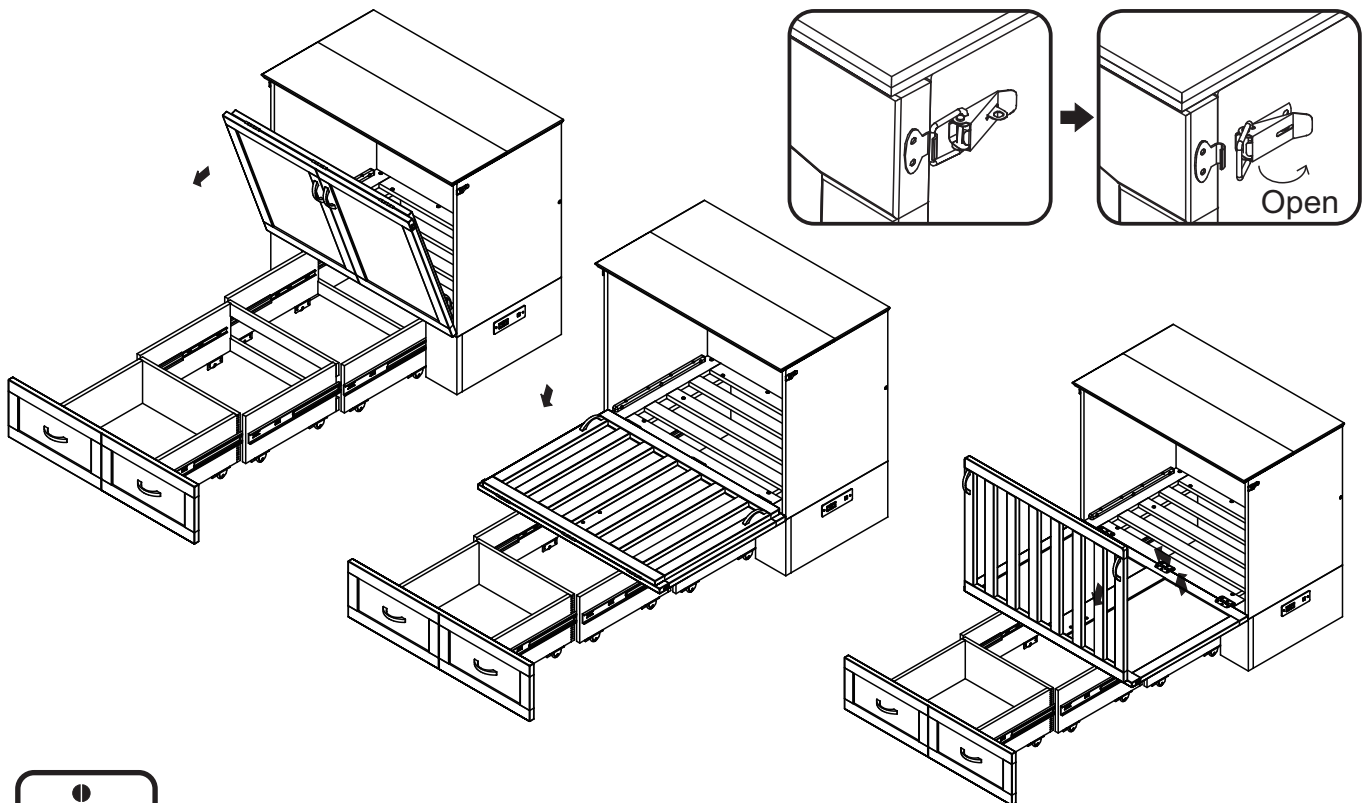

TWIN XL

STEP 12 Install folding mattress (09) to the bed.

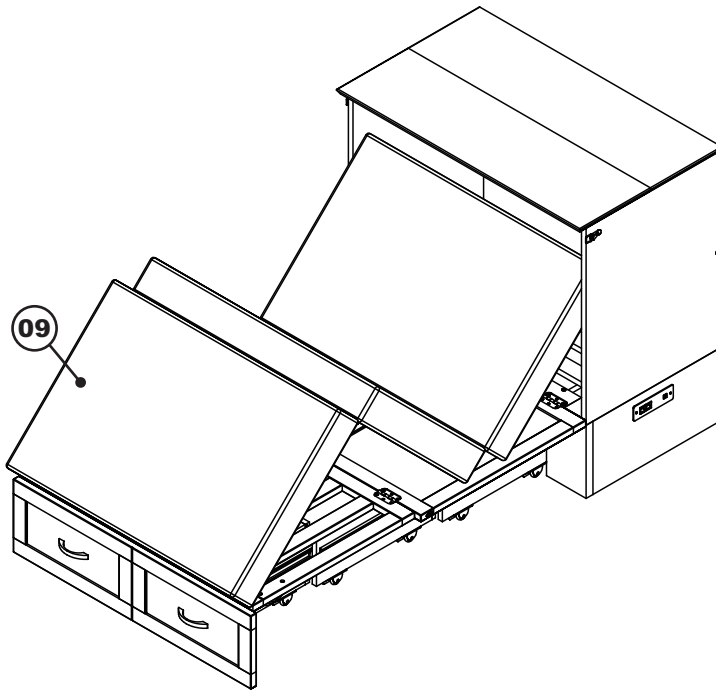

STEP 13 Open top panel and push drawer base in as shown below.

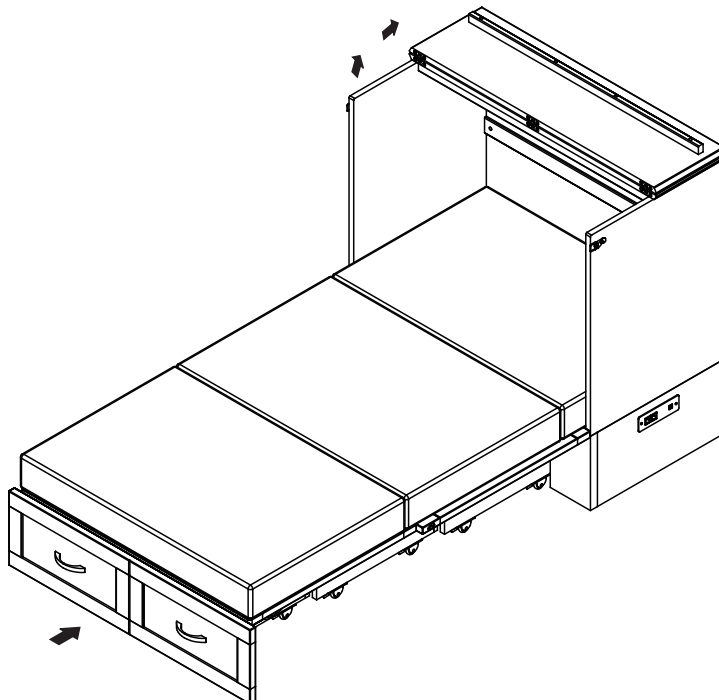

Congratulations!

Your Murphy bed is now ready for use.

We recommend that you recheck that all screws are tight, and that all parts are secure before use to ensure lasting Safety.