

ASSEMBLY INSTRUCTION FOR ACME FURNITURE











MODEL # 27327EK-HB - EK STORAGE HEADBOARD











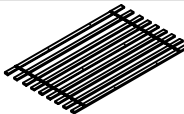

MODEL# 27328EK-FB - EK STORAGE FOOTBOARD

MODEL#27329EK/Q-R E.KING QUEEN BED-STORAGE RAILS

Thank you for purchasing this quality product. Be sure to check all packing material carefully for small parts which may have come loose inside the carton during shipment. Separate, identify and count all parts and metal hardware. Compare with parts list to be sure all parts are present. If any part (S) are missing or damaged, please contact your local furniture dealer. For efficient and speedy service, please indicate the model number and code letter of parts (s) when needed.

Do not fully tighten screws until fully assembled

| HARDWARE LIST | | | | |
|---------------|---------------|---|--------------|--------|
| No | Description | Sketch | Size | Qty |
| A | Allen Bolt |  | 5/16"X35mm | 13pcs |
| B | Allen Bolt |  | 5/16"X55mm | 10pcs |
| C | Lock Washer |  | 5/16" | 23pcs |
| D | Flat Washer |  | 5/16"X19X2mm | 23pcs |
| E | Allen Key |  | 4mm | 1 pc |
| F | Cotter Nut |  | 1/4"X35mm | 10sets |
| G | Holder |  | 170X18X15mm | 2 pcs |
| H | Hax-Headbolts |  | 5/32"X20mm | 4 pcs |
| I | Screw |  | #8X25mm | 34pcs |
| J | Screw |  | #8X12mm | 2 |

| No. | Description | Sketch | Qty |
|-----|----------------------------|---|-------|
| 1 | Headboard Panel |  | 1 pc |
| 2 | Footboard |  | 1 pc |
| 3 | Headboard Post |  | 2 pcs |
| 4 | Side Rails |  | 2 pcs |
| 5 | Headboard bottom stretcher |  | 1 pc |
| 6 | Slat Roll |  | 1 Set |
| 7 | Support Leg |  | 9 pcs |
| 8 | Drawer box |  | 1 pc |
| 9 | Drawer Front Panel |  | 2 pcs |
| 10 | Drawer Side Panel |  L/R | 4 pcs |
| 11 | Drawer Back Panel |  | 2 pcs |
| 12 | Drawer Bottom Panel |  | 2 pcs |
| 13 | Drawer Bottom Support |  | 2 pcs |
| 14 | Box Support Leg |  | 2 pcs |

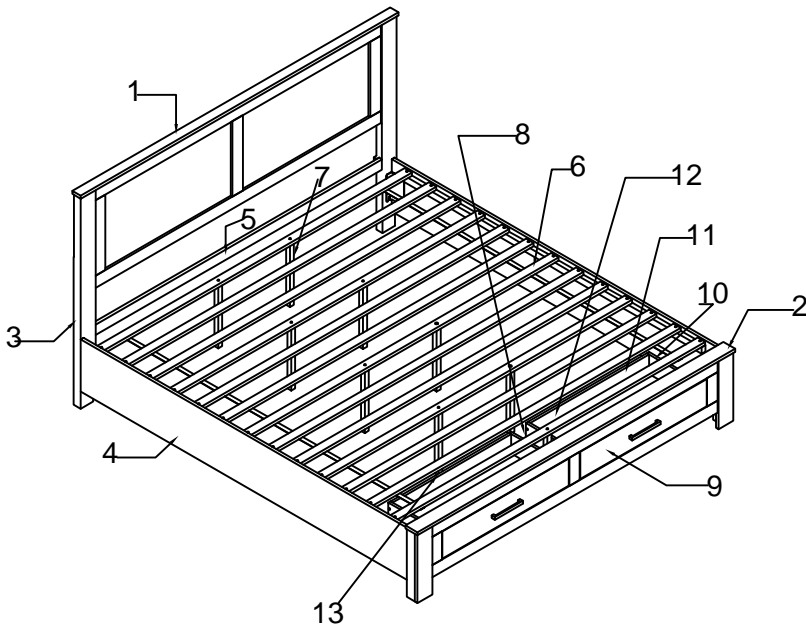

ASSEMBLY INSTRUCTION FOR ACME FURNITURE

MODEL # 27327EK-HB - EK STORAGE HEADBOARD

MODEL# 27328EK-FB - EK STORAGE FOOTBOARD

MODEL#27329EK/Q-R E.KING QUEEN BED-STORAGE RAILS

Thank you for purchasing this quality product. Be sure to check all packing material carefully for small parts which may have come loose inside the carton during shipment. Separate, identify and count all parts and metal hardware. Compare with parts list to be sure all parts are present. If any part (S) are missing or damaged, please contact your local furniture dealer. For efficient and speedy service, please indicate the model number and code letter of parts (s) when needed.

Do not fully tighten screws until fully assembled

STEP 1

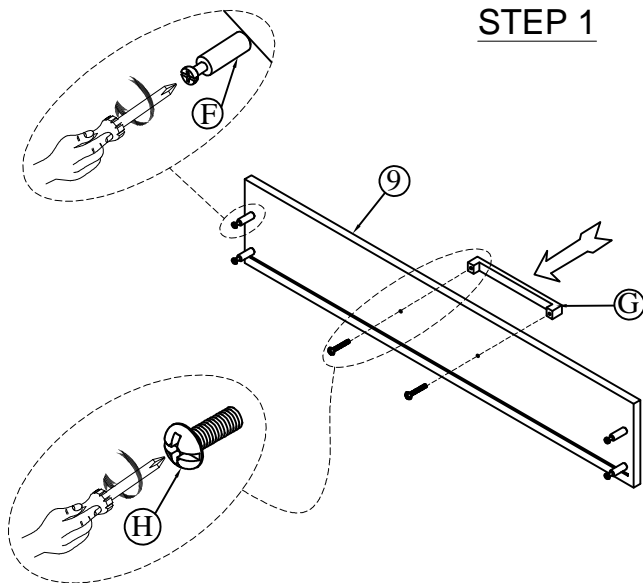

STEP 2

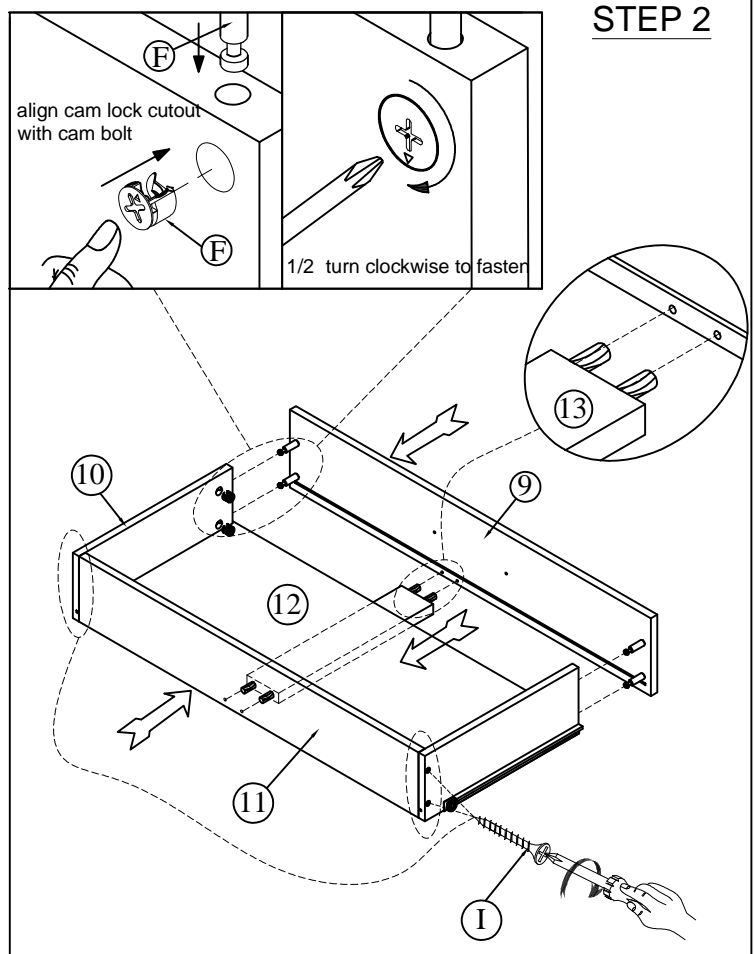

Completed Drawer

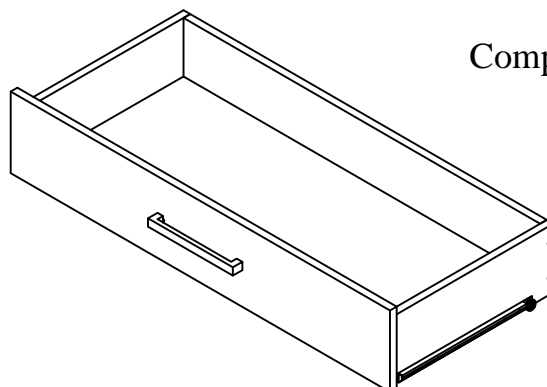

ASSEMBLY INSTRUCTION FOR ACME FURNITURE

MODEL # 27327EK-HB - EK STORAGE HEADBOARD

MODEL# 27328EK-FB - EK STORAGE FOOTBOARD

MODEL#27329EK/Q-R E.KING QUEEN BED-STORAGE RAILS

Thank you for purchasing this quality product. Be sure to check all packing material carefully for small parts which may have come loose inside the carton during shipment. Separate, identify and count all parts and metal hardware. Compare with parts list to be sure all parts are present. If any part (S) are missing or damaged, please contact your local furniture dealer. For efficient and speedy service, please indicate the model number and code letter of parts (S) when needed.

Do not fully tighten screws until fully assembled

STEP 3

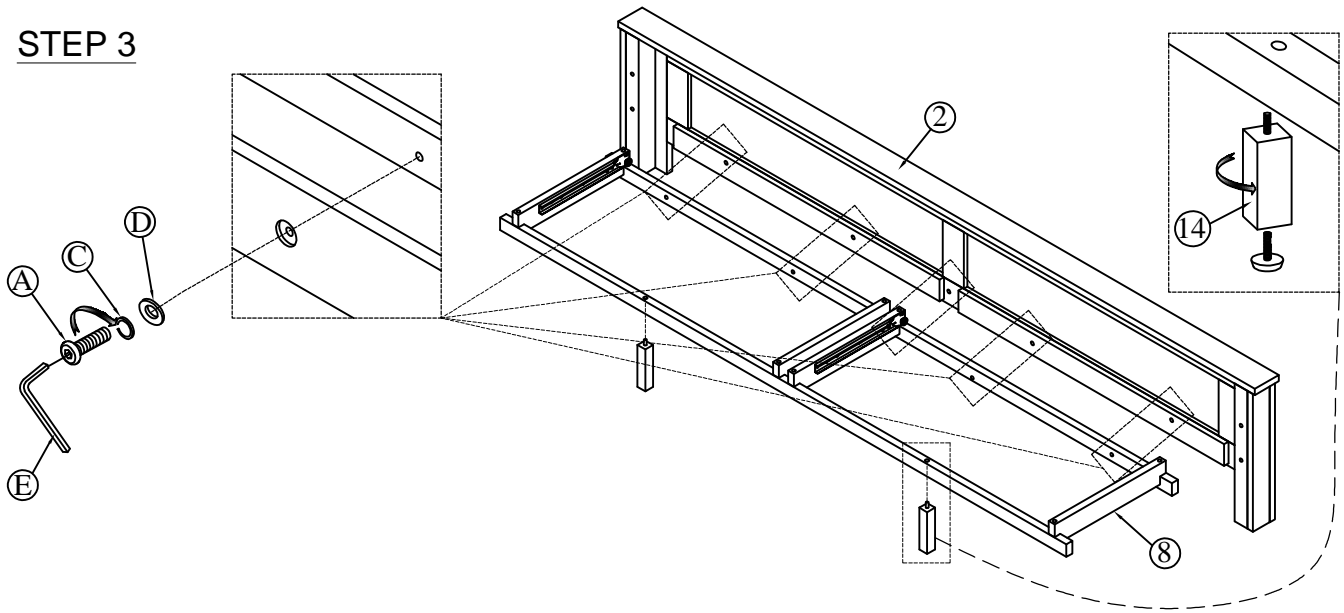

STEP 4

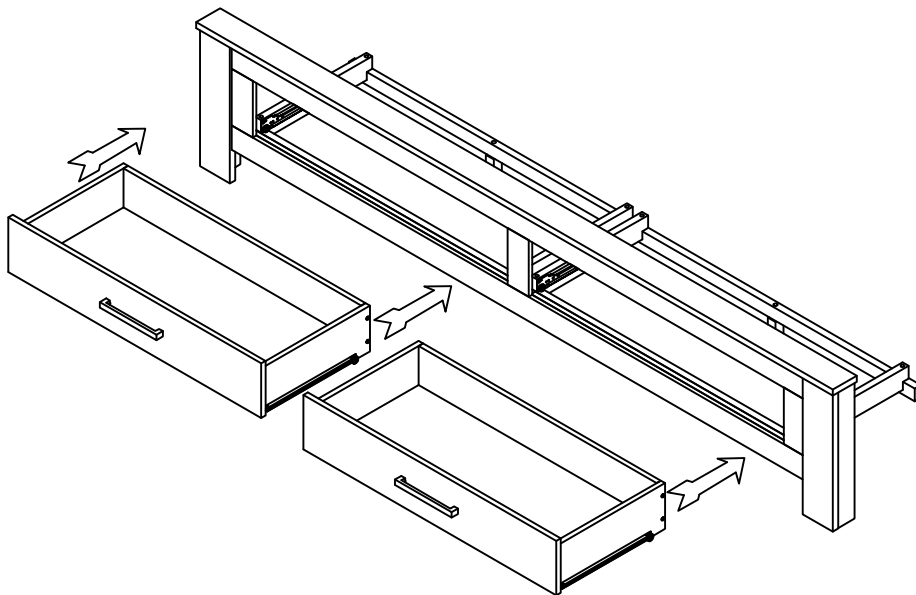

ASSEMBLY INSTRUCTION FOR ACME FURNITURE

MODEL # 27327EK-HB - EK STORAGE HEADBOARD

MODEL# 27328EK-FB - EK STORAGE FOOTBOARD

MODEL#27329EK/Q-R E.KING QUEEN BED-STORAGE RAILS

Thank you for purchasing this quality product. Be sure to check all packing material carefully for small parts which may have come loose inside the carton during shipment. Separate, identify and count all parts and metal hardware. Compare with parts list to be sure all parts are present. If any part (S) are missing or damaged, please contact your local furniture dealer. For efficient and speedy service, please indicate the model number and code letter of parts (s) when needed.

Do not fully tighten screws until fully assembled

