

STEP 6 Required Fittings : D x 8 pcs B x 8 pcs F x 4 pcs K x 8 pcs
 Attach Head & Footboard With Side Rails

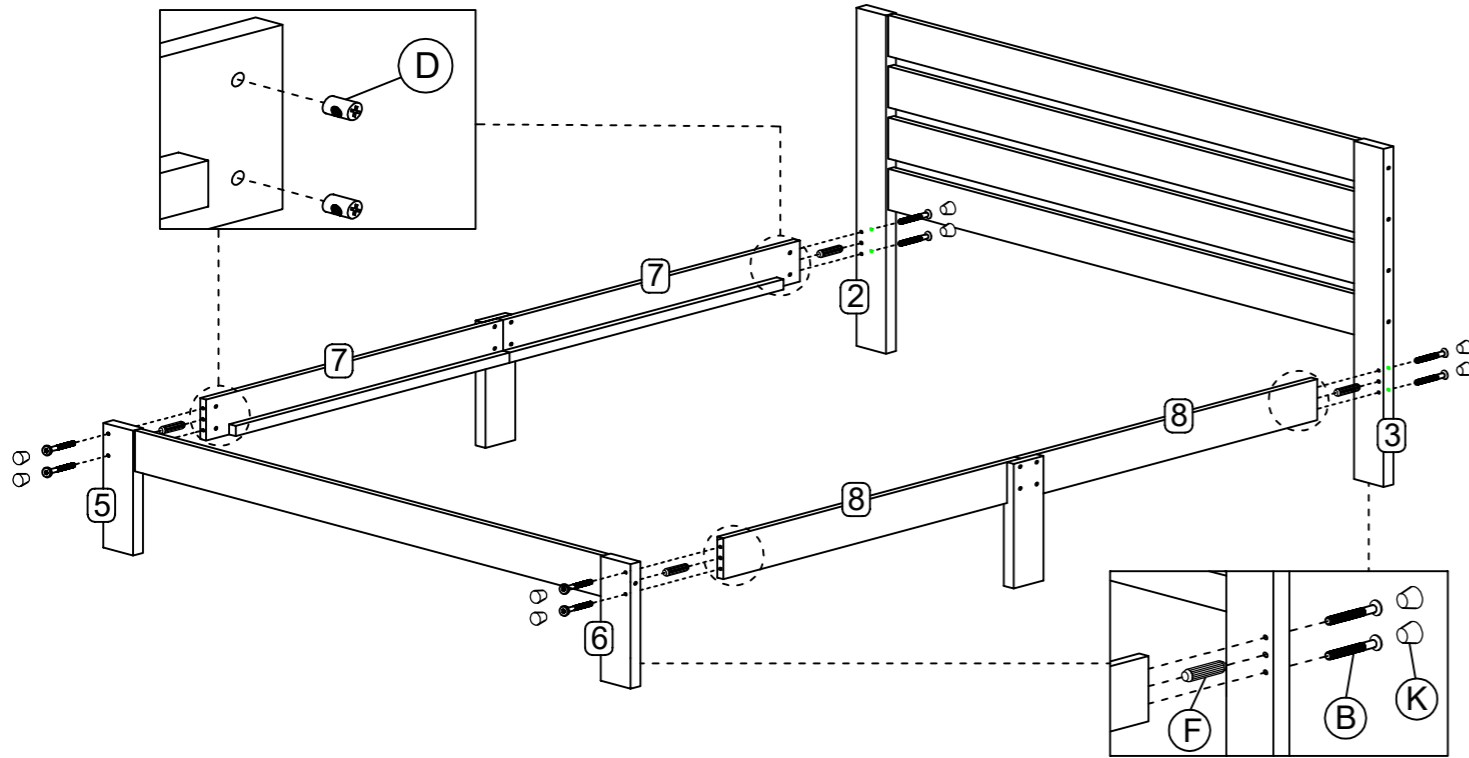

STEP 7 Required Fittings : G x 36 pcs
 Attach Slats To Bed Frame.

- Useful Tips :
- Carefully place those slats onto the bed frame to prevent scratches.
 - Slot in the assembled center support from underneath the bed.
 - Drill in the first and last piece of slats in order to hold the position before drilling the rest of the slats.

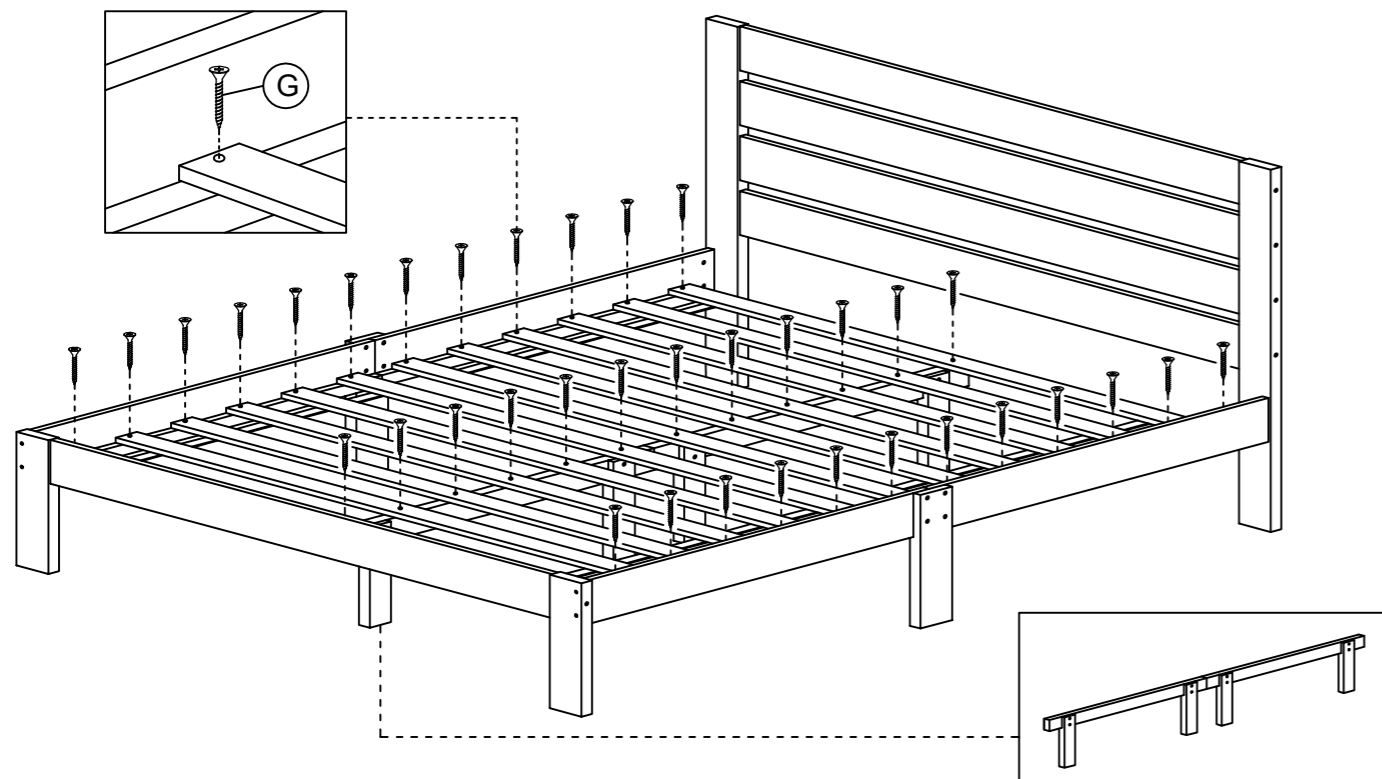

ASSEMBLY INSTRUCTIONS

ACME Furniture

Double bed frame

BEFORE YOU START,
 HERE IS SOME
 HELPFUL ADVICE

We suggest you spend a short time reading through this leaflet and follow the simple step-by-step assembly instructions.

Do not discard any of the packaging until you have checked that you have all the parts and the pack of fittings.

Assemble this product on a flat surface.

Assemble all parts loosely before tightening any bolts.

Discard all extra fittings and keep fittings out of reach of children.

To clean, wipe clean with a damp cloth.

Retain Assembly Instruction for future reference.

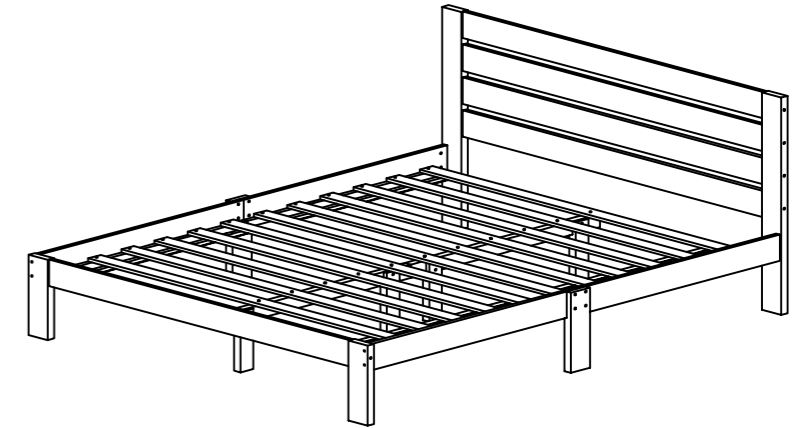

PARTS AND FITTINGS LIST

PARTS LIST		
CODE	DESCRIPTION	QTE.
1	HEADBOARD PANEL	4
2	HEADBOARD POST (LEFT)	1
3	HEADBOARD POST (RIGHT)	1
4	FOOTBOARD PANEL	1
5	FOOTBOARD POST (LEFT)	1
6	FOOTBOARD POST (RIGHT)	1
7	SIDE RAIL (LEFT)	2
8	SIDE RAIL (RIGHT)	2
9	SIDE RAIL CENTER LEG	2
10	CENTER SUPPORT	2
11	SUPPORT LEG	4
12	SLATS	2 SET

FITTINGS LIST		
CODE	DESCRIPTION	QTE.
A	JCBC M6 x 110mm	10
B	JCBC M6 x 70mm	8
C	JCBC M6 x 30mm	16
D	BARREL NUT M6 x 15mm	18
E	JCN M6 x 15mm	8
F	WOOD DOWEL M10 x 40mm	4
G	CSK SCREW M4 x 25mm	36
H	ALLEN KEY M4	2
I	WOOD DOWEL M8 x 30mm	20
J	WOOD DOWEL M10 x 25mm	4
K	WOOD BUTTON	18

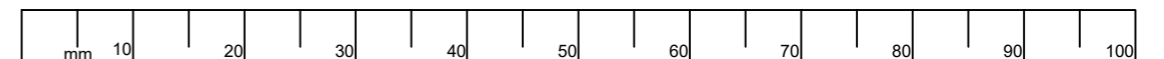
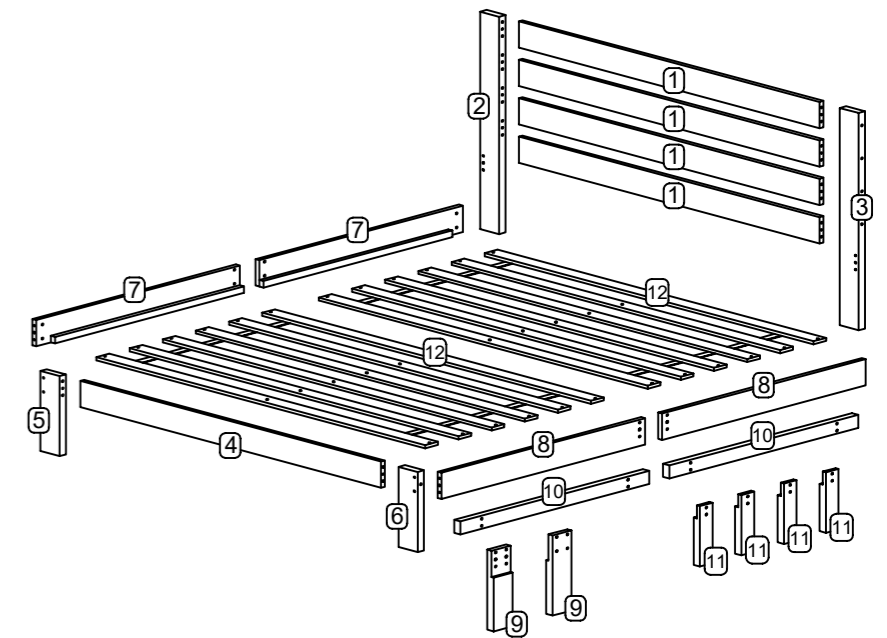

STEP 1 Required Fittings : A x 8 pcs D x 8 pcs I x 16 pcs K x 8 pcs
 1. Headboard Assembly.

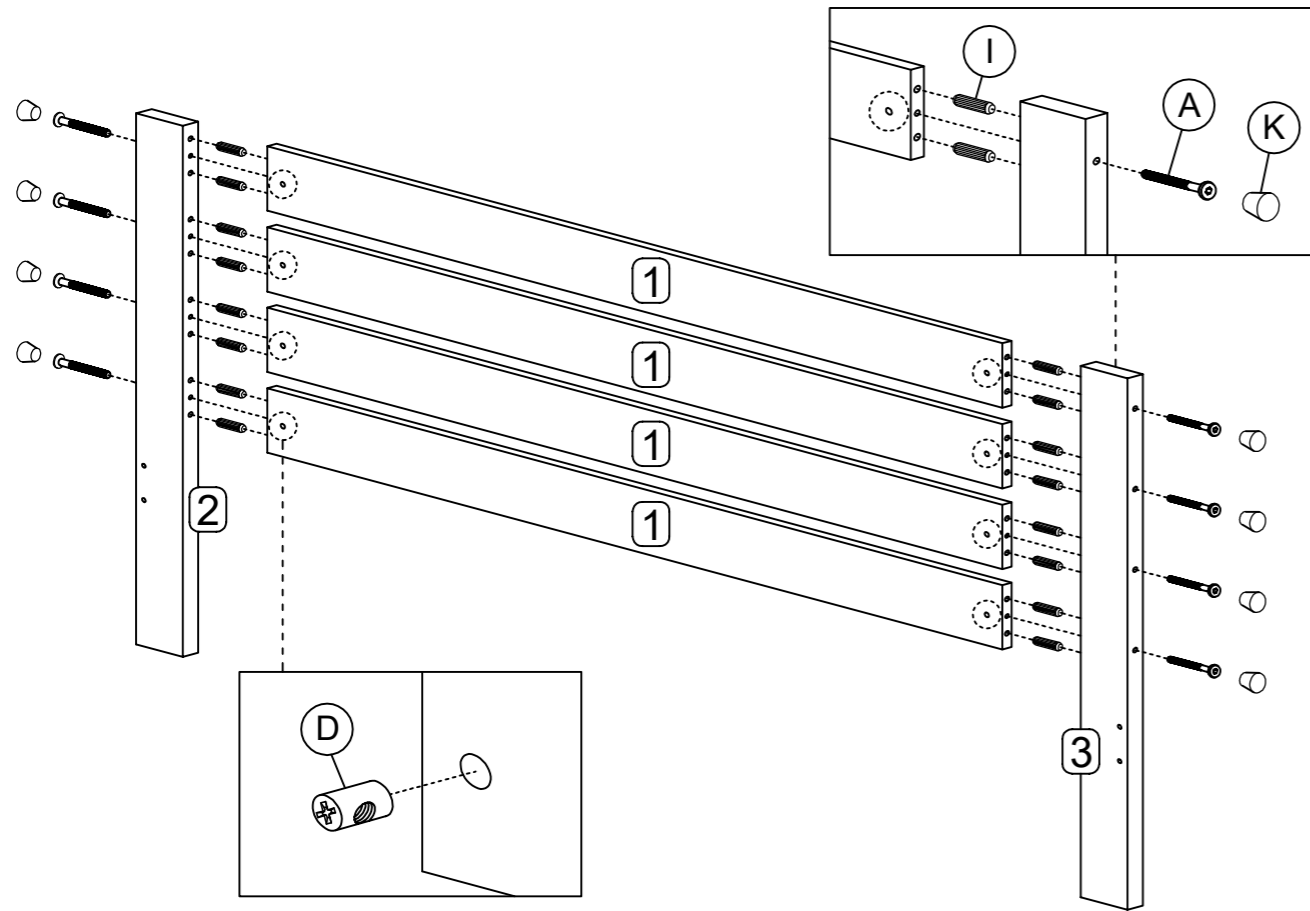

STEP 2 Required Fittings : A x 2 pcs D x 2 pcs I x 4 pcs K x 2 pcs
 1. Footboard Assembly.

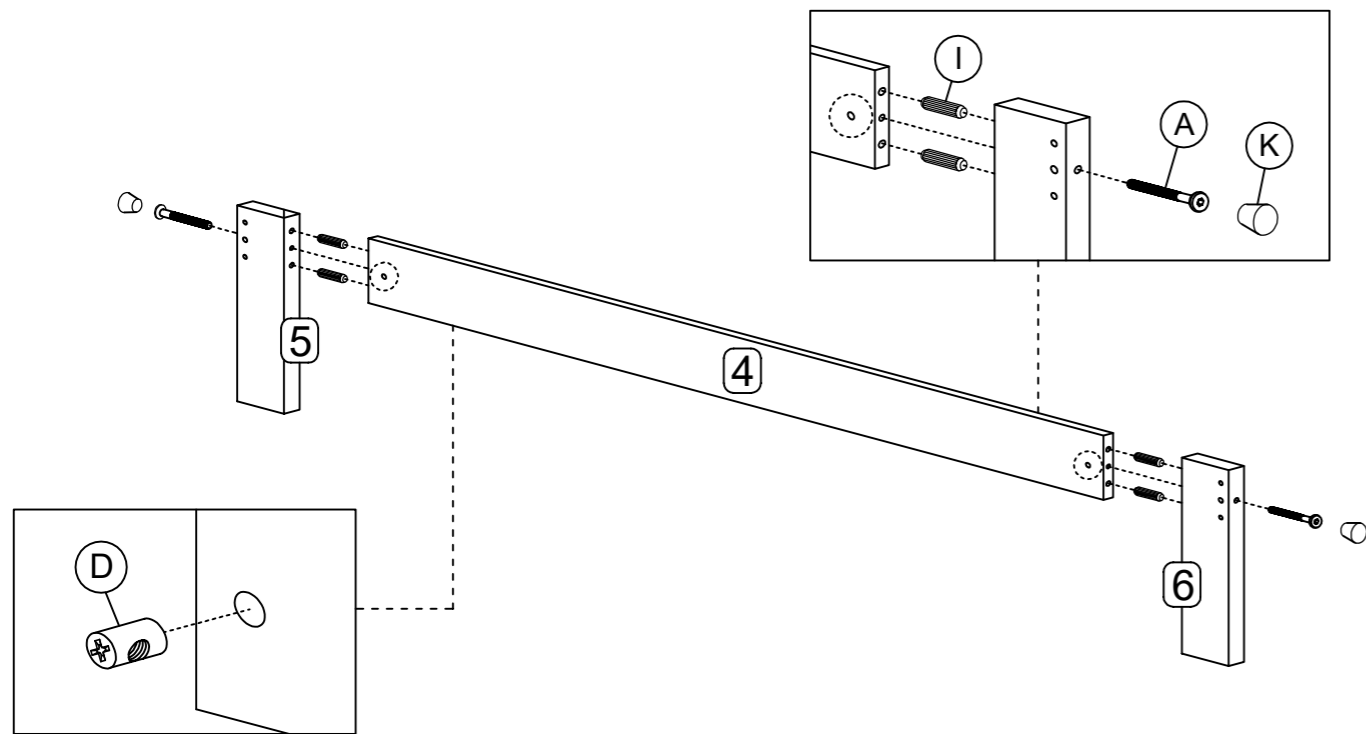

STEP 3 Required Fittings : C x 4 pcs J x 2 pcs E x 4 pcs H x 2 pcs
 1. Attach Side Rail (Left) With Side Rail Center Leg.

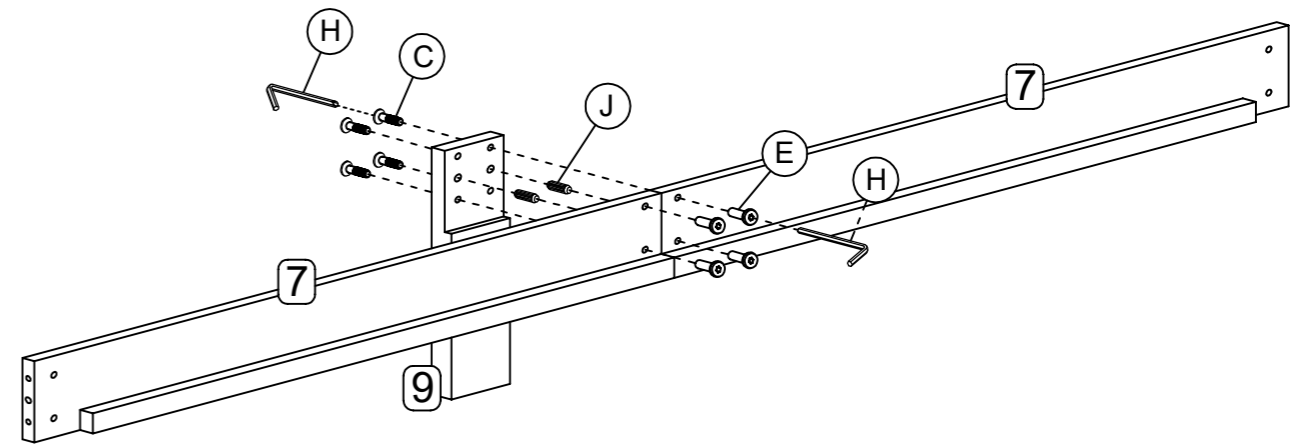

STEP 4 Required Fittings : E x 4 pcs J x 2 pcs C x 4 pcs H x 2 pcs
 1. Attach Side Rail (Right) With Side Rail Center Leg.

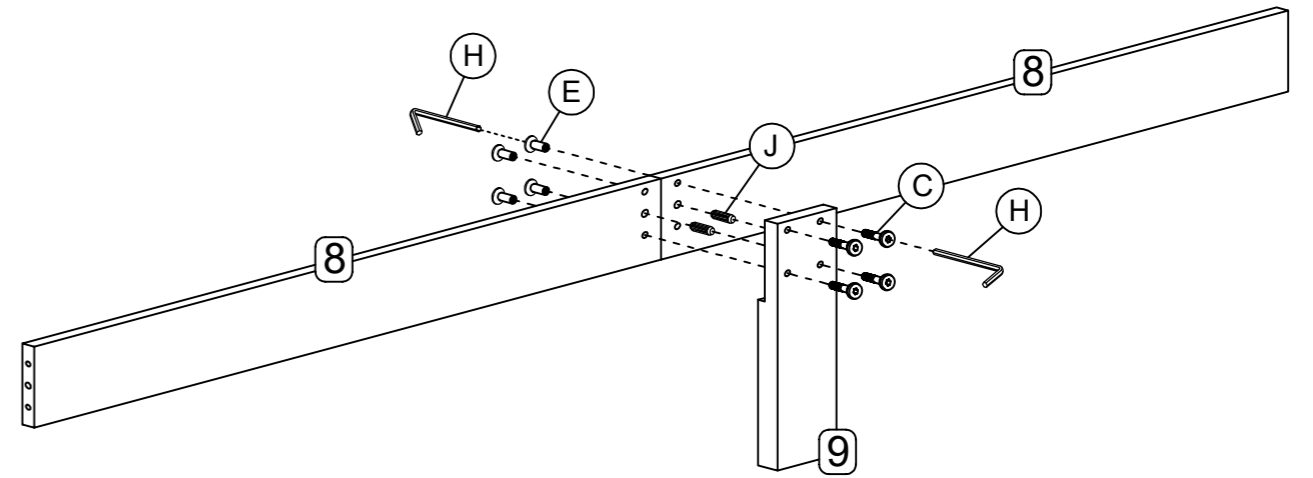

STEP 5 Required Fittings : C x 8 pcs
 1. Assemble support legs with center support.

