







ASSEMBLY INSTRUCTIONS

ITEM NO : 5203BK-K-HB / 5203BK-KQ-HBPL / 5203BK-K-FB /
5203BK-KQ-RL-L / 5203BK-KQ-RL-R
KING BED







**(BOX 1)
BOX OF HEADBOARD**

ITEM	DRAWING	DESCRIPTION	QTY
A		HEADBOARD	1
B		HEADBOARD LEG SUPPORT	2
C		WOODEN SLAT	4

**(BOX 2)
BOX OF FOOTBOARD**

ITEM	DRAWING	DESCRIPTION	QTY
G		FOOTBOARD STORAGE (L / R)	2
H		BED LEG	20
I		WOODEN SUPPORT WITH ADJUSTER	8

**(BOX 2)
BOX OF FOOTBOARD
HARDWARE LIST**

ITEM	DRAWING	DESCRIPTION	QTY
1		ALLEN KEY (M4)	1
2		CONNECTION BOLT (M6 x 35mm) W/SPRING WASHER & WASHER MEDIUM	25
3		CONNECTION BOLT (M6 x 40mm)	8
4		CSK SCREW (M4 x 32mm)	28
5		PLASTIC DOWEL (M8 x 30mm)	4
6		SCREW DRIVER (*)	1

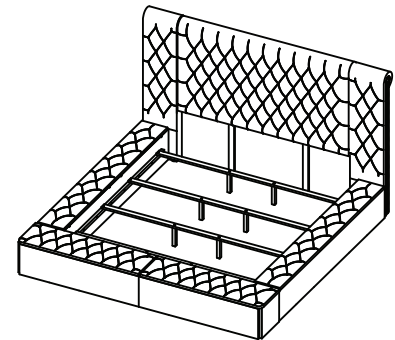

**COMPLETED KING BED
ASSEMBLY**

**(BOX 3)
BOX OF HEADBOARD WING**

ITEM	DRAWING	DESCRIPTION	QTY
D		HEADBOARD WING (L / R)	2

**(BOX 4)
BOX OF RAIL STORAGE - L**

ITEM	DRAWING	DESCRIPTION	QTY
E		RAIL STORAGE (LEFT)	1

**(BOX 5)
BOX OF RAIL STORAGE - R**

ITEM	DRAWING	DESCRIPTION	QTY
F		RAIL STORAGE (RIGHT)	1

(*) The Manufacturer does not provide item 6.

STEP 1

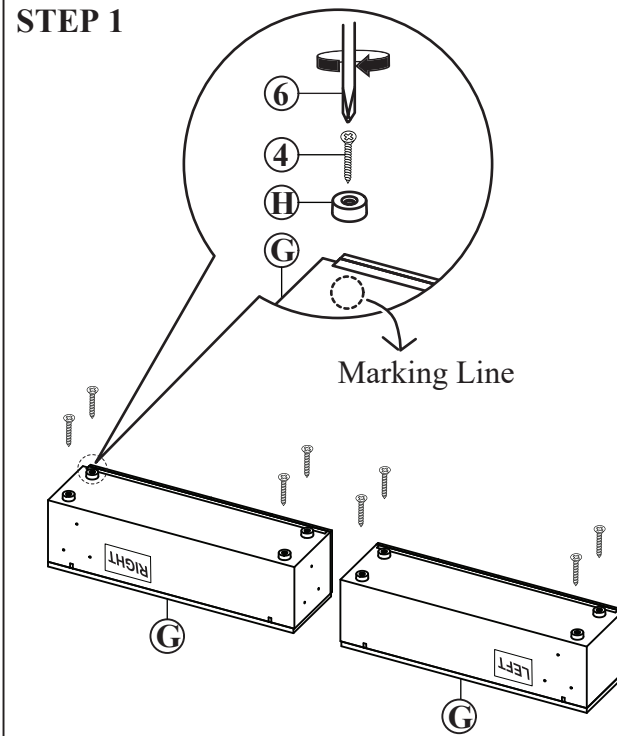

STEP 2

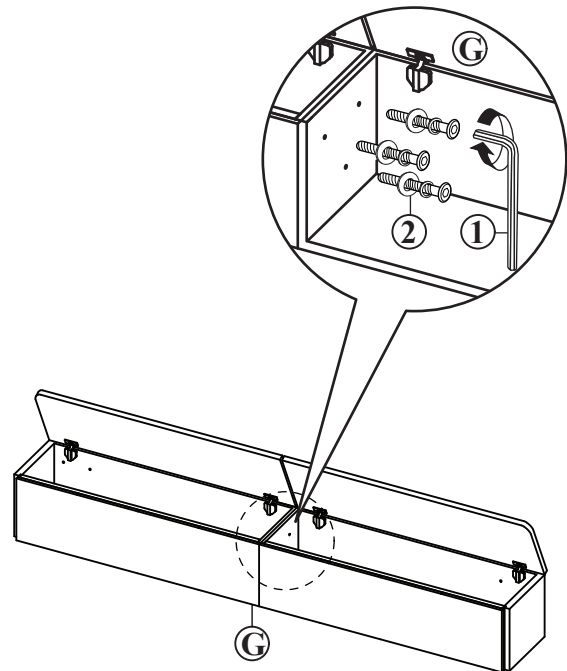

THE HARDWARE IS LOCATED IN THE PACKING ITEMS.

NOTE : MUST TIGHTEN BOLTS & SCREWS PERIODICALLY. WITH USE BOLTS & SCREWS MAY BECOME LOOSE.
CHECK TIGHTNESS OF ALL BOLTS & SCREWS EVERY 6-8 WEEKS.

CLEANING INSTRUCTION

After assembly, clean & polish the completed parts if necessary with soft cloth and industrial recognized furniture polish

MADE IN MALAYSIA

ASSEMBLY INSTRUCTIONS

ITEM NO : 5203BK-K-HB / 5203BK-KQ-HBPL / 5203BK-K-FB /
5203BK-KQ-RL-L / 5203BK-KQ-RL-R
KING BED

STEP 3

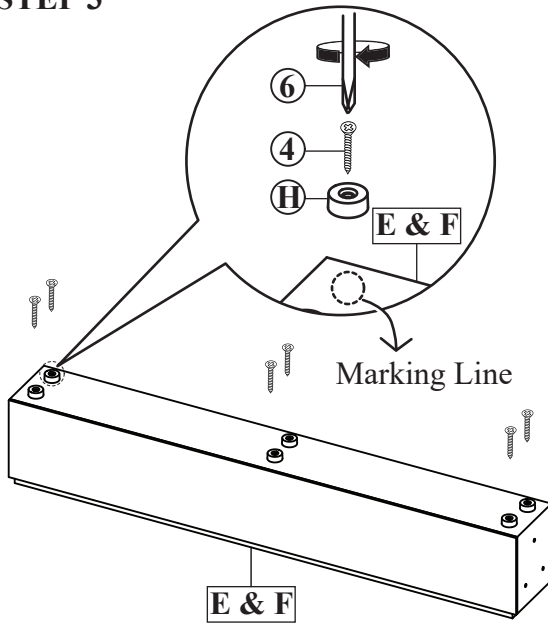

STEP 4

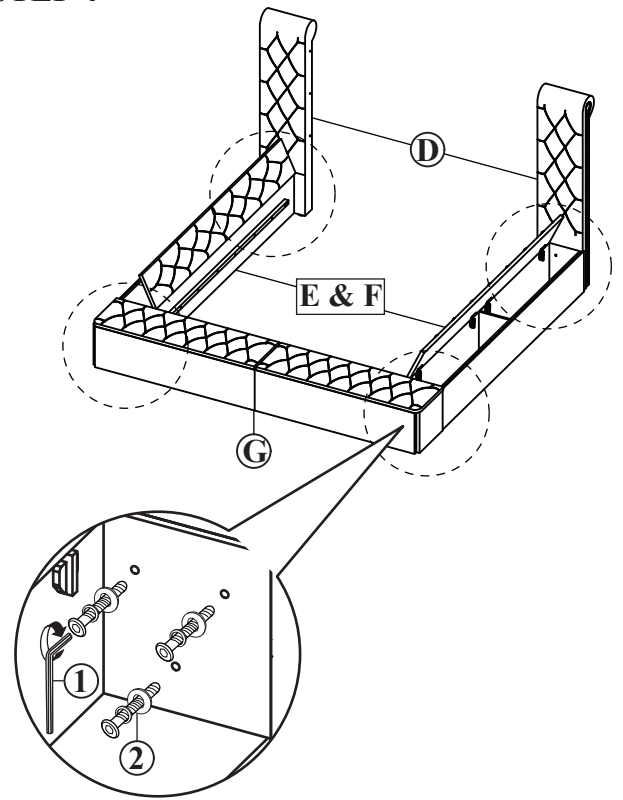

STEP 5

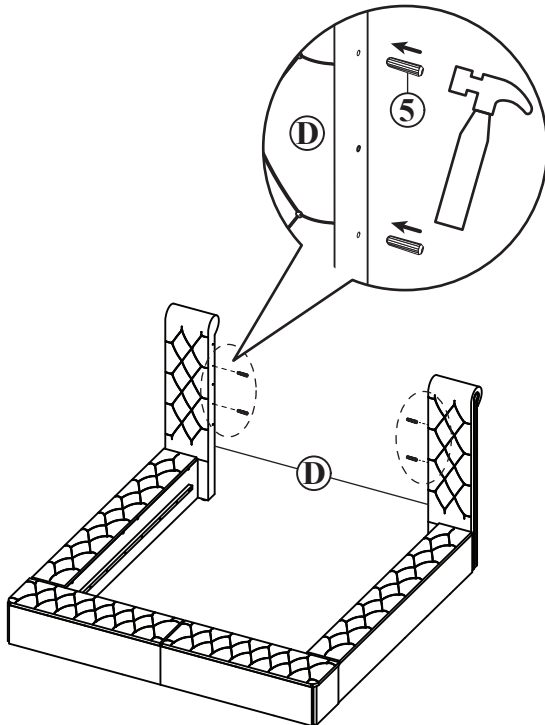

STEP 6

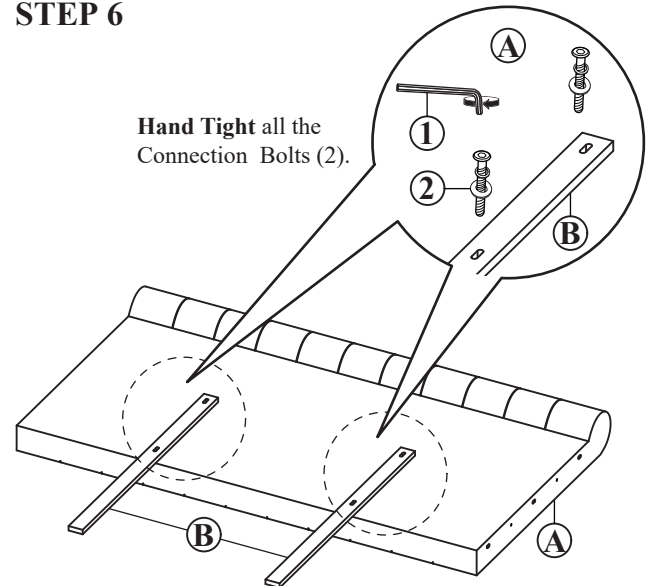

THE HARDWARE IS LOCATED IN THE PACKING ITEMS.

NOTE : MUST TIGHTEN BOLTS & SCREWS PERIODICALLY. WITH USE BOLTS & SCREWS MAY BECOME LOOSE.
CHECK TIGHTNESS OF ALL BOLTS & SCREWS EVERY 6-8 WEEKS.

CLEANING INSTRUCTION

After assembly, clean & polish the completed parts if necessary with soft cloth and industrial recognized furniture polish

MADE IN MALAYSIA

ASSEMBLY INSTRUCTIONS

ITEM NO : 5203BK-K-HB / 5203BK-KQ-HBPL / 5203BK-K-FB /
5203BK-KQ-RL-L / 5203BK-KQ-RL-R
KING BED

STEP 7

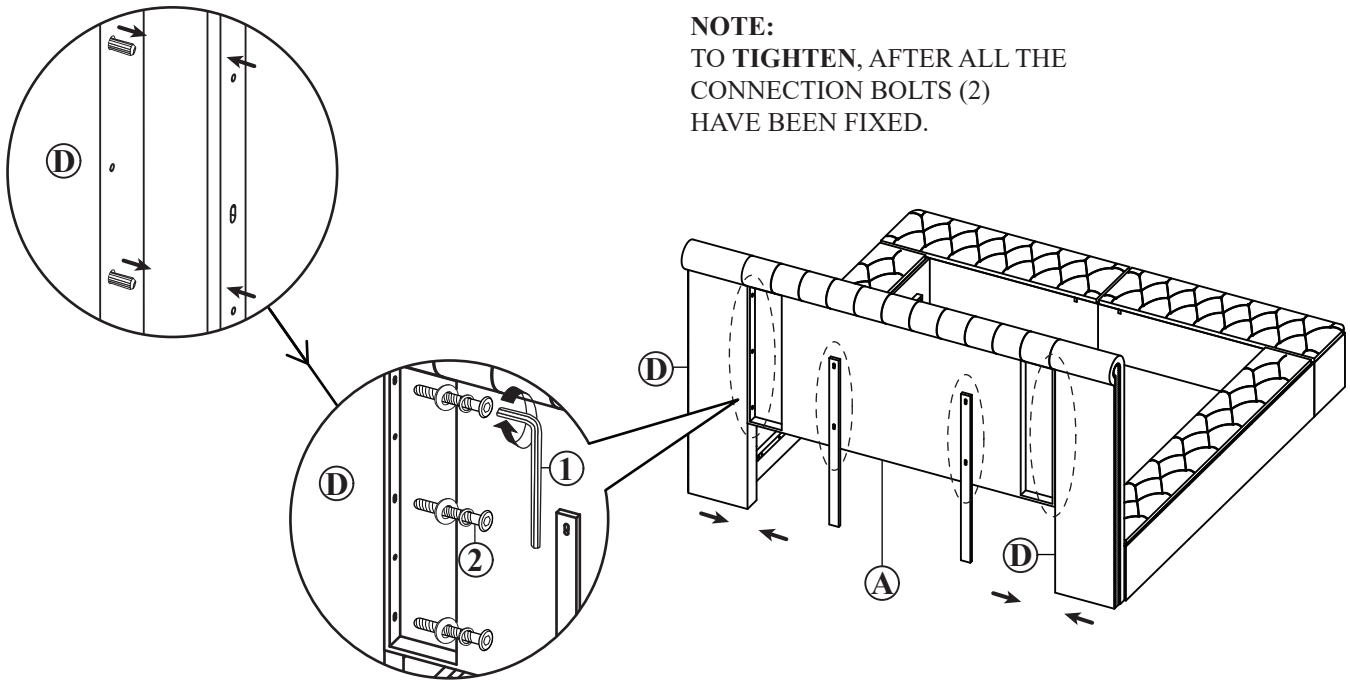

STEP 8

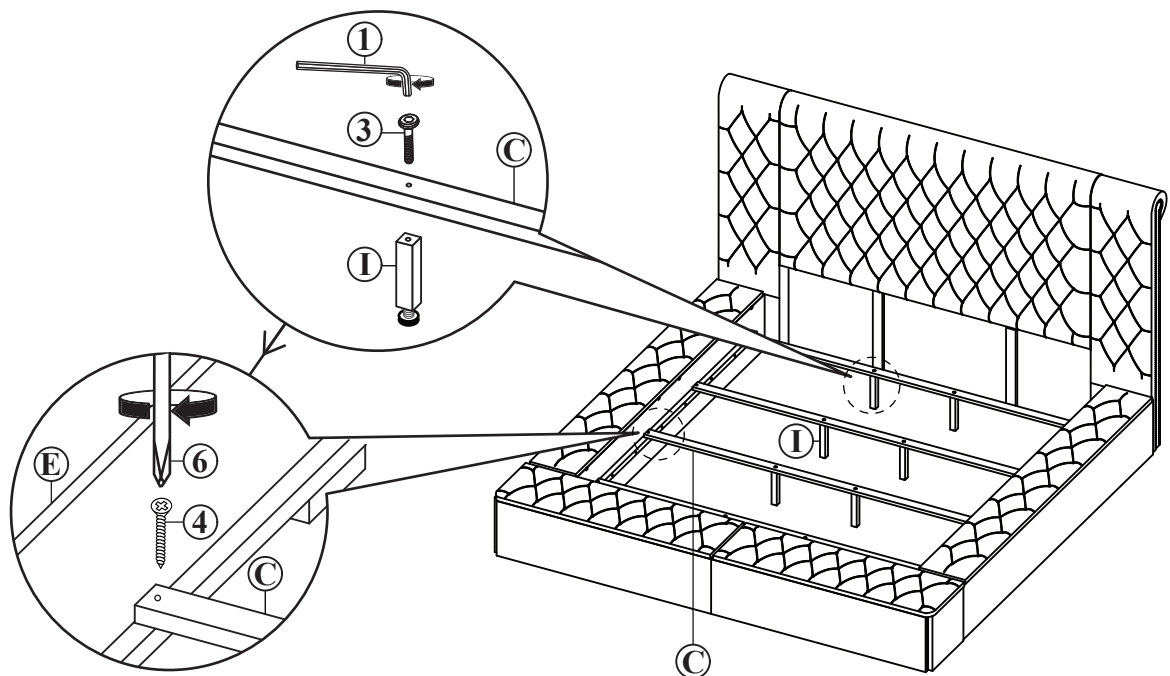

CLEANING INSTRUCTION



After assembly, clean & polish the completed parts if necessary with soft cloth and industrial recognized furniture polish

MADE IN MALAYSIA



ASSEMBLY INSTRUCTIONS

ITEM NO : 5203BK-Q-HB / 5203BK-KQ-HBPL / 5203BK-Q-FB /
5203BK-KQ-RL-L / 5203BK-KQ-RL-R
QUEEN BED







**(BOX 1)
BOX OF HEADBOARD**

ITEM	DRAWING	DESCRIPTION	QTY
A		HEADBOARD	1
B		HEADBOARD LEG SUPPORT	2
C		WOODEN SLAT	4

**(BOX 2)
BOX OF FOOTBOARD**

ITEM	DRAWING	DESCRIPTION	QTY
G		FOOTBOARD STORAGE	1
H		BED LEG	18
I		WOODEN SUPPORT WITH ADJUSTER	4

**(BOX 2)
BOX OF FOOTBOARD
HARDWARE LIST**

ITEM	DRAWING	DESCRIPTION	QTY
1		ALLEN KEY (M4)	1
2		CONNECTION BOLT (M6 x 35mm) W/SPRING WASHER & WASHER MEDIUM	22
3		CONNECTION BOLT (M6 x 40mm)	4
4		CSK SCREW (M4 x 32mm)	26
5		PLASTIC DOWEL (M8 x 30mm)	4
6		SCREW DRIVER (*)	1

(*) The Manufacturer does not provide item 6.

**(BOX 3)
BOX OF HEADBOARD WING**

ITEM	DRAWING	DESCRIPTION	QTY
D		HEADBOARD WING (L / R)	2

**(BOX 4)
BOX OF RAIL STORAGE - L**

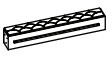
ITEM	DRAWING	DESCRIPTION	QTY
E		RAIL STORAGE (LEFT)	1

**(BOX 5)
BOX OF RAIL STORAGE - R**

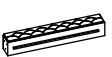
ITEM	DRAWING	DESCRIPTION	QTY
F		RAIL STORAGE (RIGHT)	1

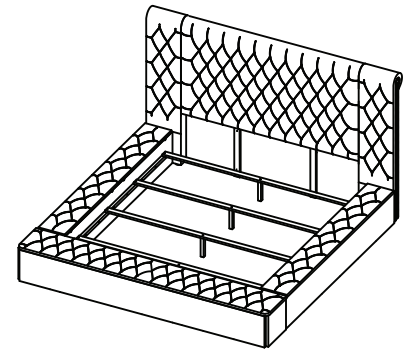

**COMPLETED QUEEN BED
ASSEMBLY**

STEP 1

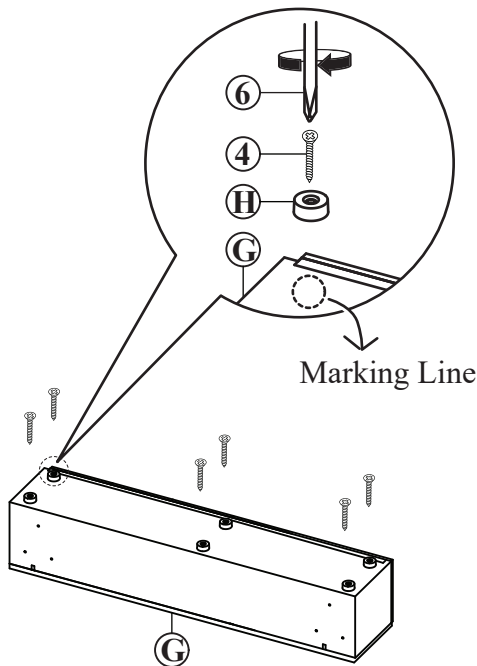

STEP 2

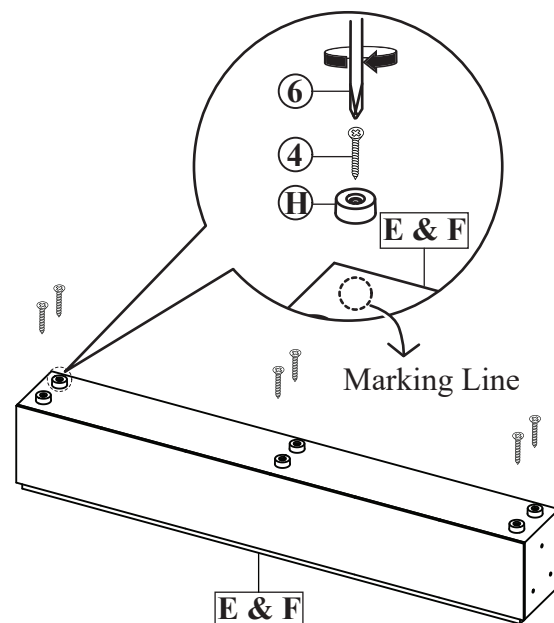

THE HARDWARE IS LOCATED IN THE PACKING ITEMS.

NOTE : MUST TIGHTEN BOLTS & SCREWS PERIODICALLY. WITH USE BOLTS & SCREWS MAY BECOME LOOSE.
CHECK TIGHTNESS OF ALL BOLTS & SCREWS EVERY 6-8 WEEKS.

CLEANING INSTRUCTION

After assembly, clean & polish the completed parts if necessary with soft cloth and industrial recognized furniture polish

MADE IN MALAYSIA

ASSEMBLY INSTRUCTIONS

ITEM NO : 5203BK-Q-HB / 5203BK-KQ-HBPL / 5203BK-Q-FB /
5203BK-KQ-RL-L / 5203BK-KQ-RL-R
QUEEN BED

STEP 3

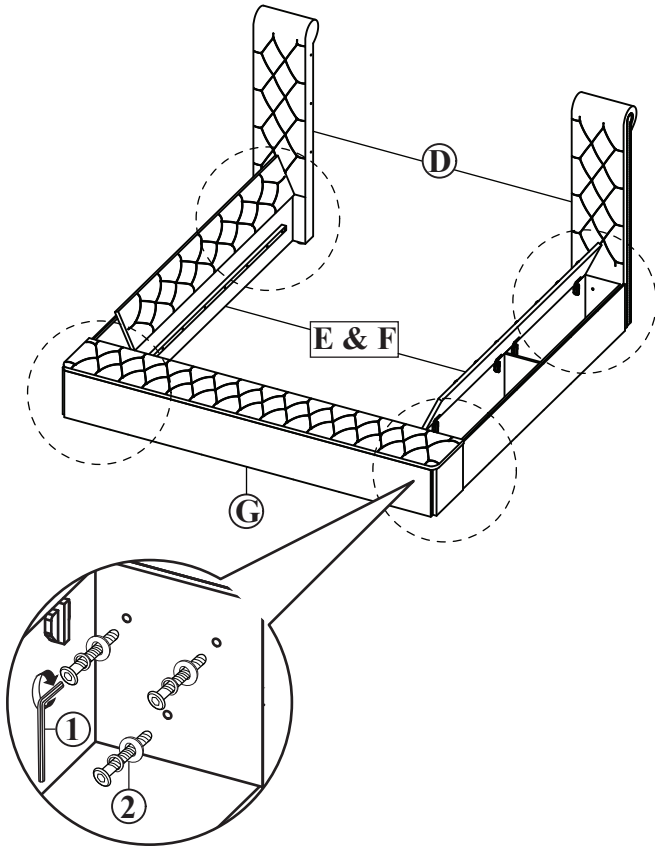

STEP 4

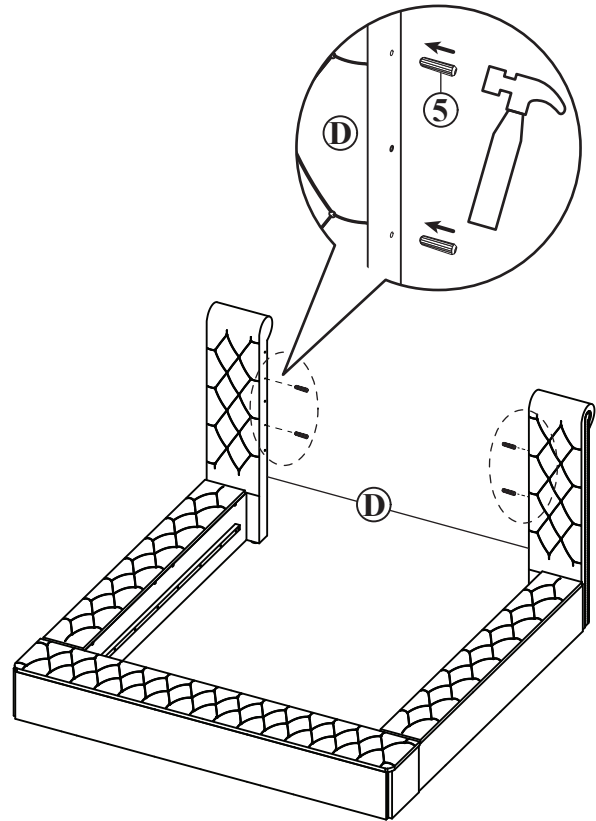

STEP 5

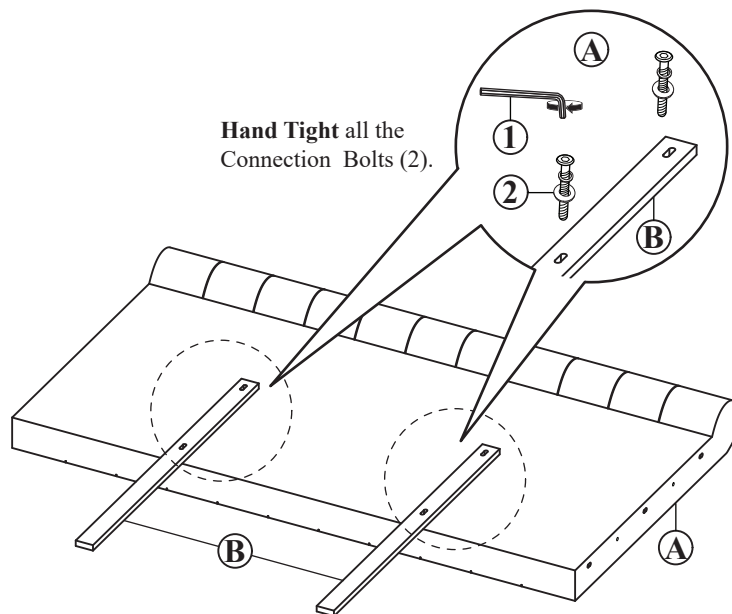

THE HARDWARE IS LOCATED IN THE PACKING ITEMS.

NOTE : MUST TIGHTEN BOLTS & SCREWS PERIODICALLY. WITH USE BOLTS & SCREWS MAY BECOME LOOSE.
CHECK TIGHTNESS OF ALL BOLTS & SCREWS EVERY 6-8 WEEKS.

CLEANING INSTRUCTION

After assembly, clean & polish the completed parts if necessary with soft cloth and industrial recognized furniture polish

MADE IN MALAYSIA

ASSEMBLY INSTRUCTIONS

ITEM NO : 5203BK-Q-HB / 5203BK-KQ-HBPL / 5203BK-Q-FB /
5203BK-KQ-RL-L / 5203BK-KQ-RL-R
QUEEN BED

STEP 6

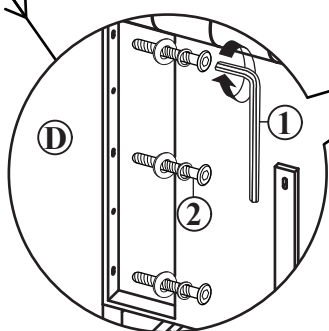
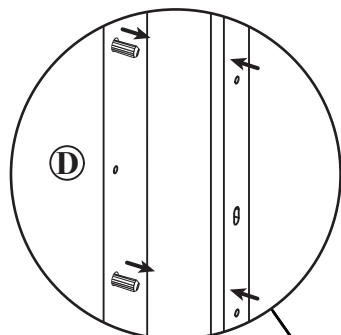

NOTE:
TO **TIGHTEN**, AFTER ALL THE
CONNECTION BOLTS (2)
HAVE BEEN FIXED.

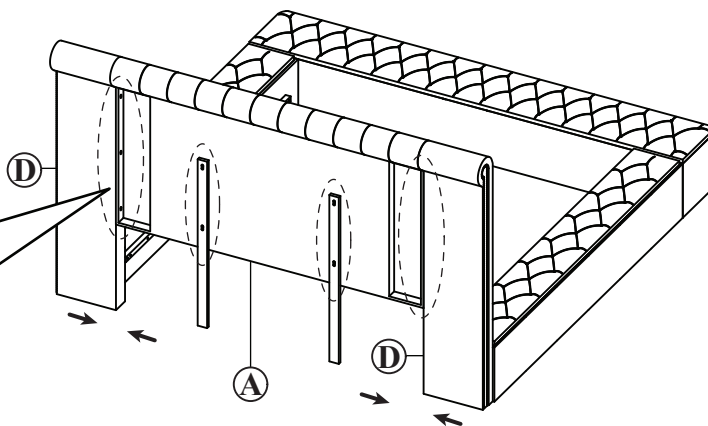

STEP 7

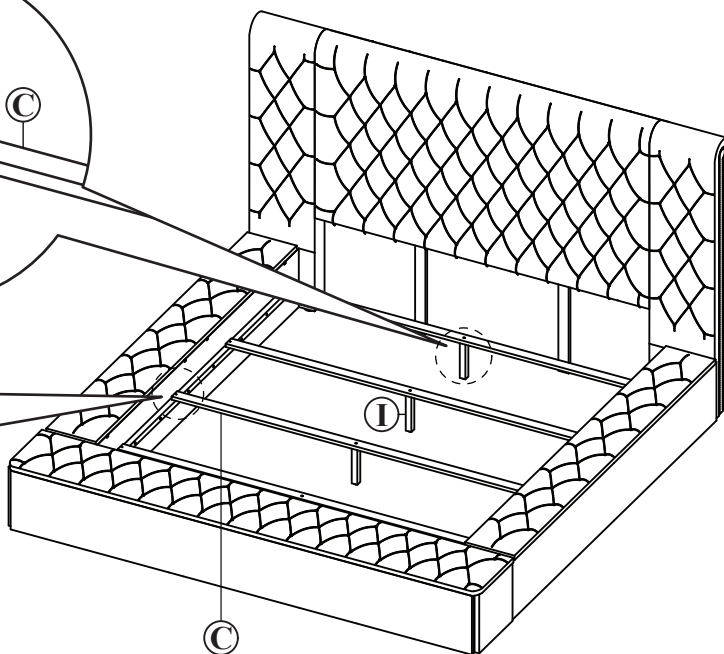
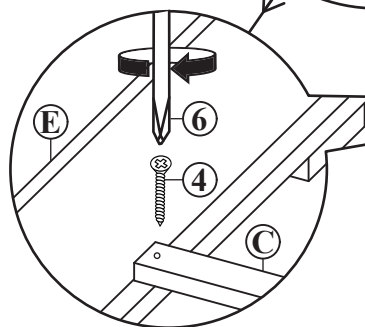
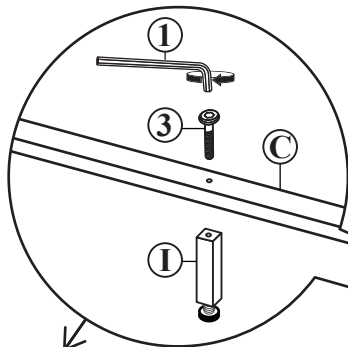

THE HARDWARE IS LOCATED IN THE PACKING ITEMS.

NOTE : MUST TIGHTEN BOLTS & SCREWS PERIODICALLY. WITH USE BOLTS & SCREWS MAY BECOME LOOSE.
CHECK TIGHTNESS OF ALL BOLTS & SCREWS EVERY 6-8 WEEKS.

CLEANING INSTRUCTION

After assembly, clean & polish the completed parts if necessary with soft cloth and industrial recognized furniture polish

MADE IN MALAYSIA