





ASSEMBLY INSTRUCTIONS

ITEM NO : B5201CL & B5201WH-Q-FB / B5201CL & B5201WH-KQ-RAIL /
B5201CL & B5201WH-Q-HBWG
QUEEN BED

**(BOX 1)
BOX OF FOOTBOARD**

ITEM	DRAWING	DESCRIPTION	QTY
A		FOOTBOARD DRAWER	1
B		BED LEG	18
C		WOODEN SLAT	4
D		WOODEN SUPPORT WITH ADJUSTER	4







**(BOX 2)
BOX OF SIDE RAIL**

ITEM	DRAWING	DESCRIPTION	QTY
E		SIDE RAIL DRAWER (L / R)	2

**(BOX 3)
BOX OF HEADBOARD WING**

ITEM	DRAWING	DESCRIPTION	QTY
F		HEADBOARD WING (L / R)	2

**(BOX 1)
HARDWARE LIST**

ITEM	DRAWING	DESCRIPTION	QTY
1		ALLEN KEY (M4)	1
2		CONNECTION BOLT (M6 x 35mm) W/SPRING WASHER & WASHER MEDIUM	18
3		CONNECTION BOLT (M6 x 40mm)	4
4		CSK SCREW (M4 x 32mm)	24
5		PLASTIC DOWEL (M8 x 30mm)	4
6		SCREW DRIVER (*)	1

(*) The Manufacturer does not provide item 6.

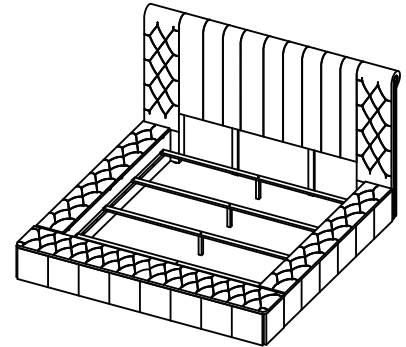

**COMPLETED QUEEN BED
ASSEMBLY**

STEP 1

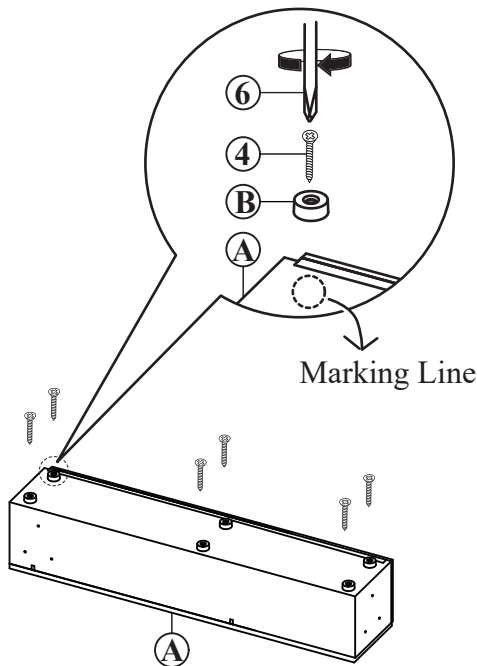

STEP 2

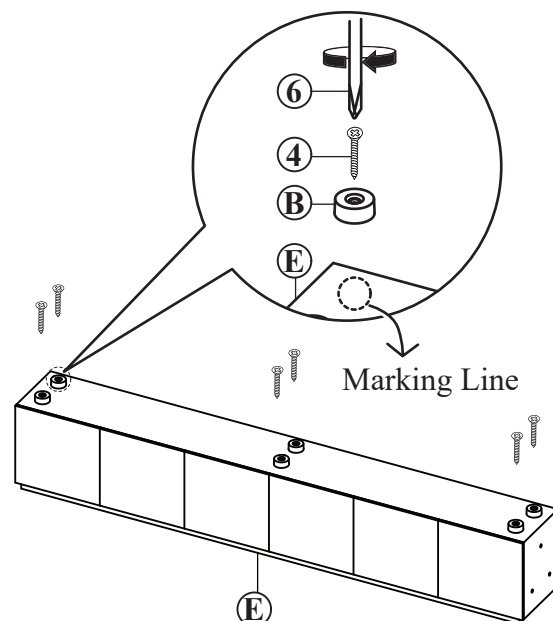

THE HARDWARE IS LOCATED IN THE PACKING ITEMS.

NOTE : MUST TIGHTEN BOLTS & SCREWS PERIODICALLY. WITH USE BOLTS & SCREWS MAY BECOME LOOSE.
CHECK TIGHTNESS OF ALL BOLTS & SCREWS EVERY 6-8 WEEKS.

CLEANING INSTRUCTION

After assembly, clean & polish the completed parts if necessary with soft cloth and industrial recognized furniture polish

MADE IN MALAYSIA

ASSEMBLY INSTRUCTIONS

ITEM NO : B5201CL & B5201WH-Q-FB / B5201CL & B5201WH-KQ-RAIL /
B5201CL & B5201WH-Q-HBWG
QUEEN BED

STEP 3

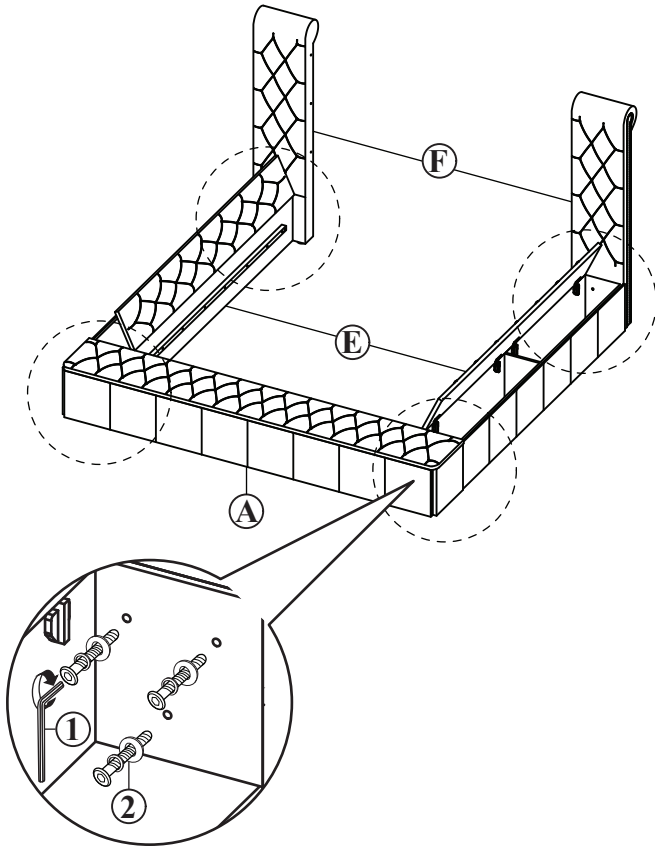

STEP 4

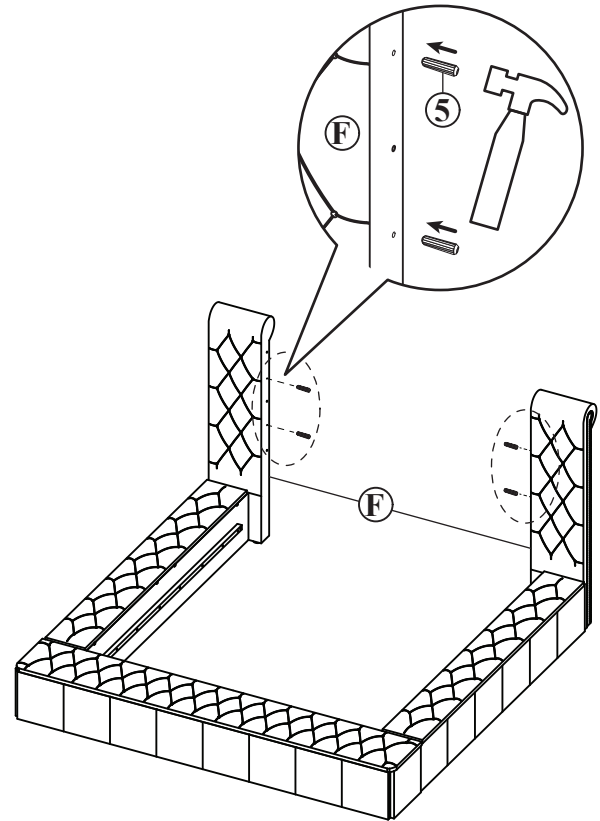

STEP 5

Please refer ITEM NO : B5201CL & B5201WH-K-HB /
B5201CL & B5201WH-Q-HB

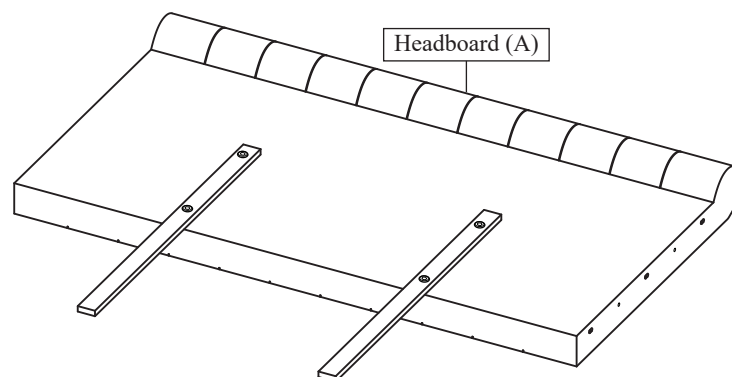

THE HARDWARE IS LOCATED IN THE PACKING ITEMS.

NOTE : MUST TIGHTEN BOLTS & SCREWS PERIODICALLY. WITH USE BOLTS & SCREWS MAY BECOME LOOSE.
CHECK TIGHTNESS OF ALL BOLTS & SCREWS EVERY 6-8 WEEKS.

CLEANING INSTRUCTION

After assembly, clean & polish the completed parts if necessary with soft cloth and industrial recognized furniture polish

MADE IN MALAYSIA

ASSEMBLY INSTRUCTIONS

ITEM NO : B5201CL & B5201WH-Q-FB / B5201CL & B5201WH-KQ-RAIL /
B5201CL & B5201WH-Q-HBWG
QUEEN BED

STEP 6

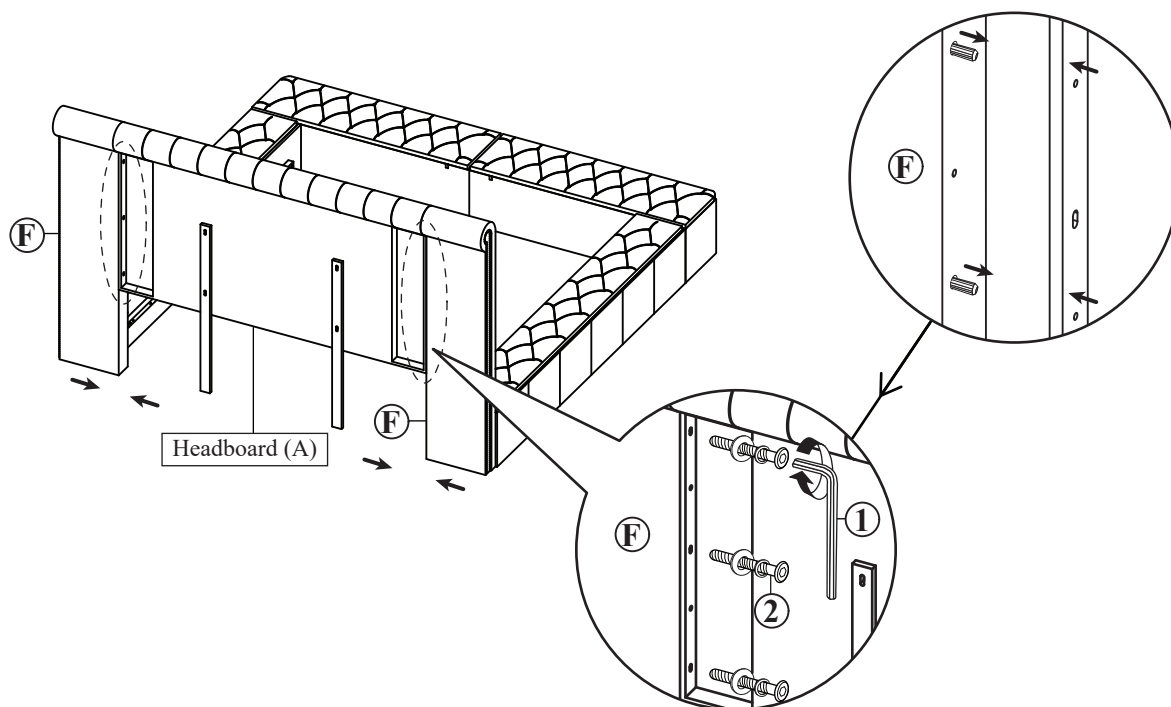

STEP 7

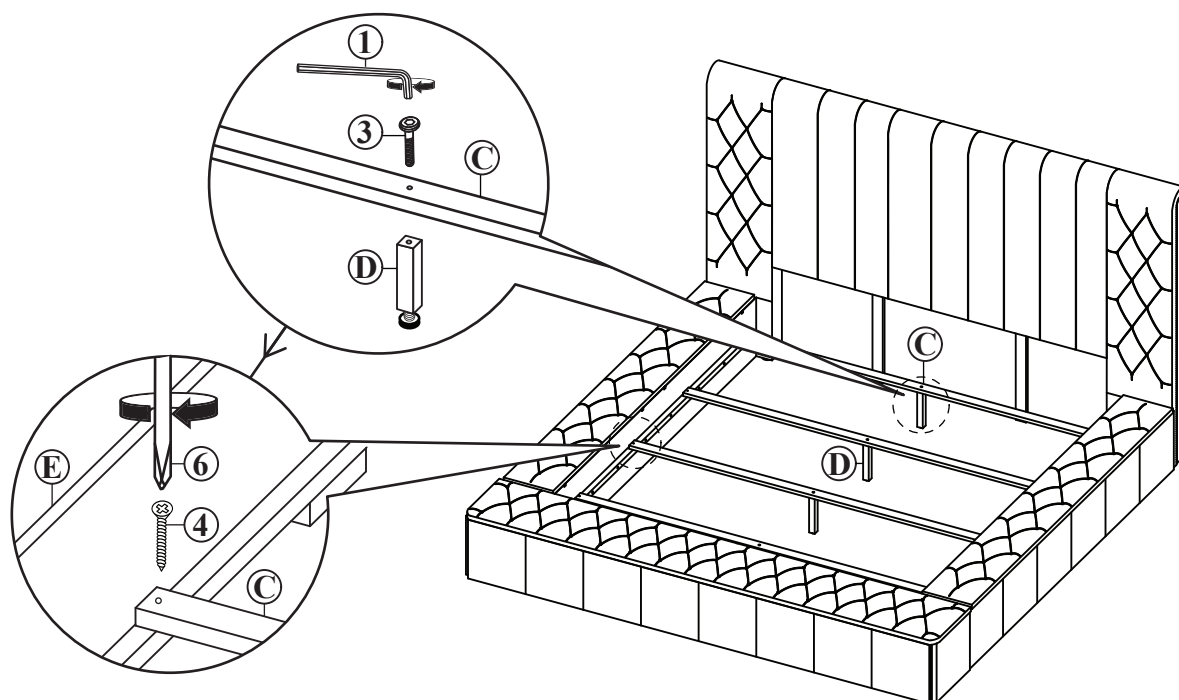

THE HARDWARE IS LOCATED IN THE PACKING ITEMS.

NOTE : MUST TIGHTEN BOLTS & SCREWS PERIODICALLY. WITH USE BOLTS & SCREWS MAY BECOME LOOSE.
CHECK TIGHTNESS OF ALL BOLTS & SCREWS EVERY 6-8 WEEKS.

CLEANING INSTRUCTION

After assembly, clean & polish the completed parts if necessary with soft cloth and industrial recognized furniture polish

MADE IN MALAYSIA