

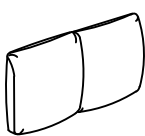

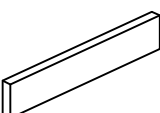

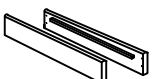





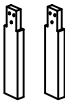

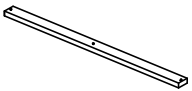
ASSEMBLY INSTRUCTION

5113WH-Q

PART LIST

(A) HEADBOARD  1PC	(B) FOOTBOARD  1PC	(C) RAIL  2PCS	(D) FB LEG  2PCS
(E) HB LEG  2PCS	(F) SUPPORT LEG  4PCS	(G) SLAT  4PCS	

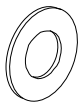
HARDWARE LIST

(H) SCREW #8X38MM  8PCS	(I) CONNECTING IRON (2L&2R)  4PCS	(J) BOLT Ø5/16" X 1-1/4"  16PCS	(K) BOLT Ø5/16" X 2-3/8"  6PCS
(L) FLAT WASHER 19MM  16PCS	(M) FLAT WASHER 22MM  6PCS	(N) LOCK WASHER 5/16"  22PCS	(O) ALLEN KEY M5  1PC

Remark: Parts B, C in one box, All other parts in other box.

STEP 1

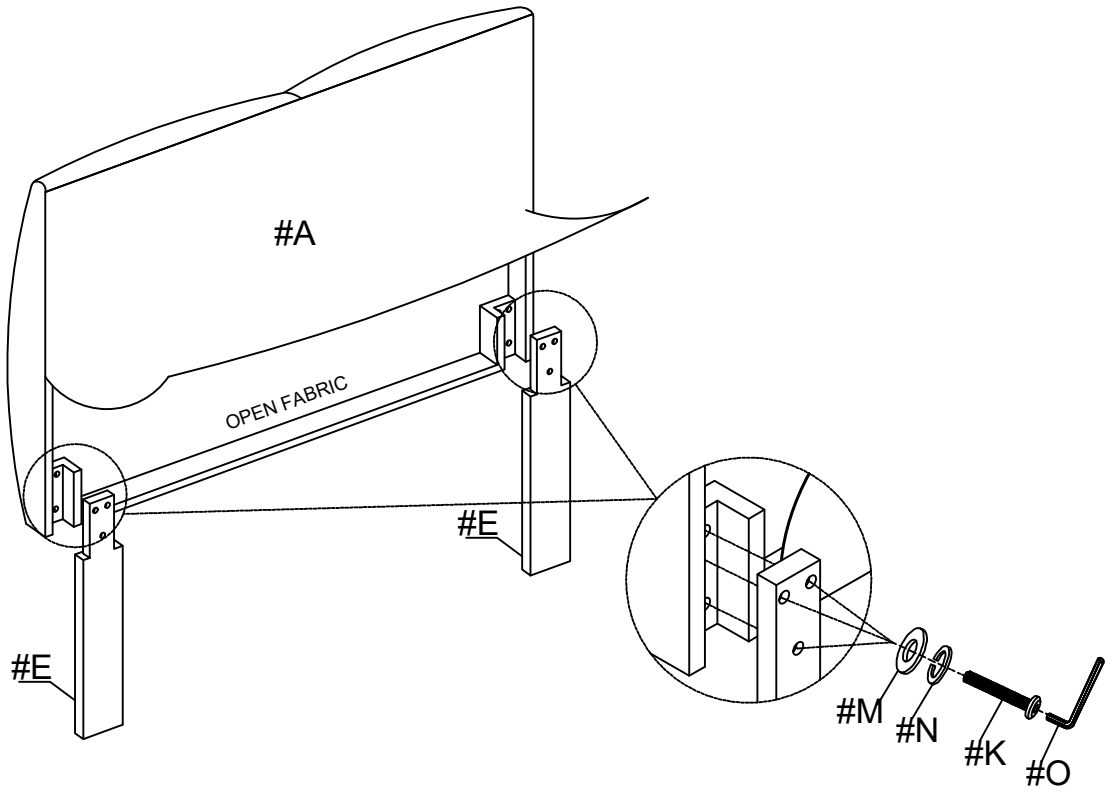

STEP 2

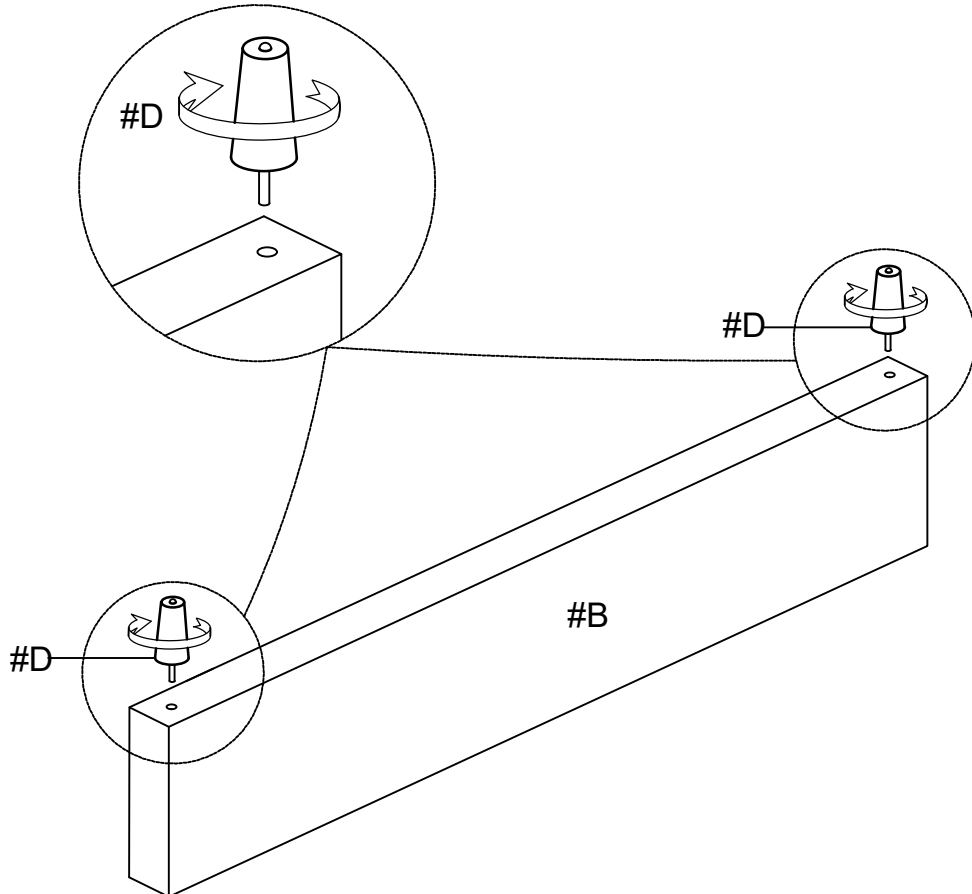

STEP 3

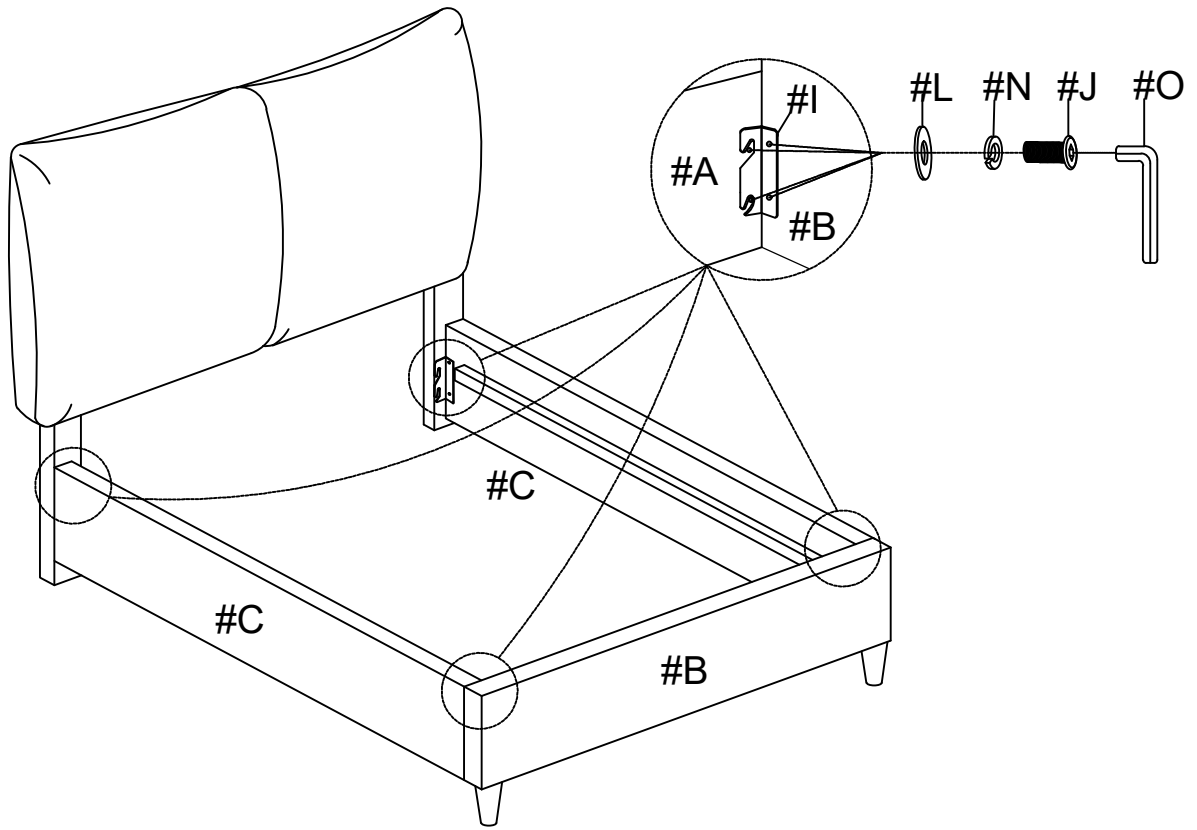

STEP 4

X4

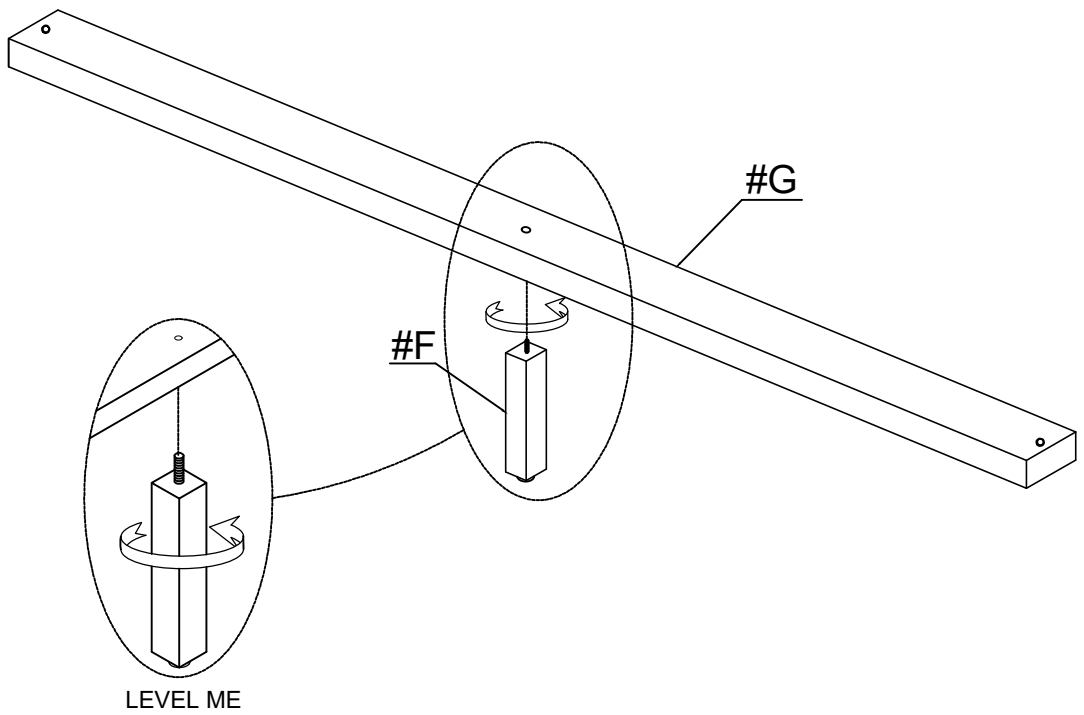

STEP 5

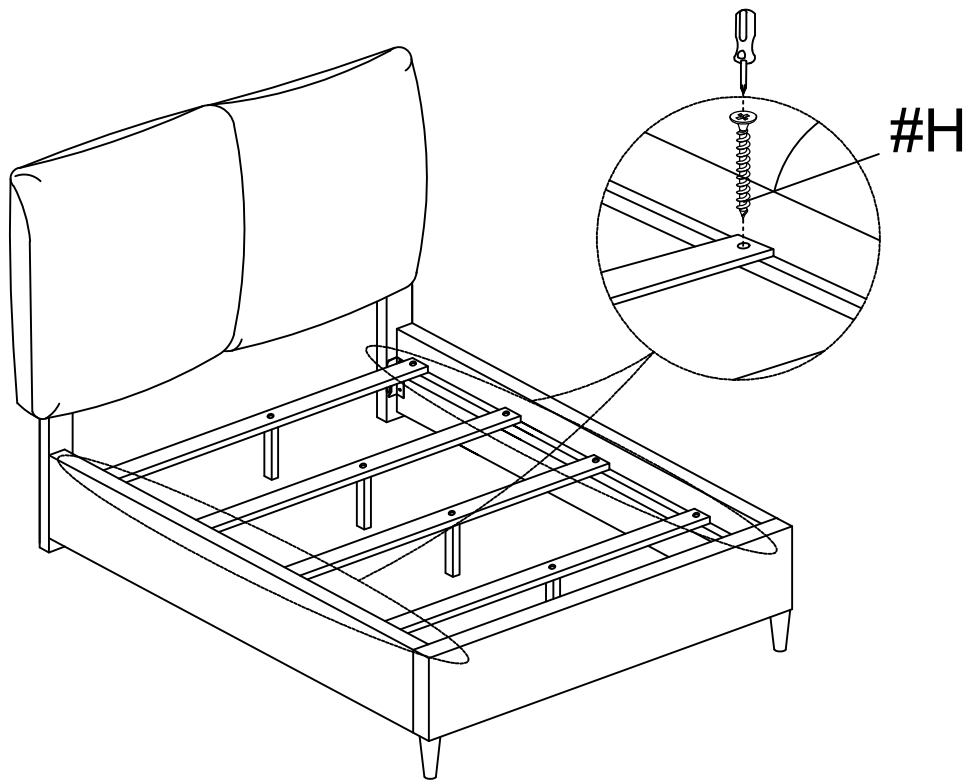

STEP 6

