











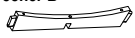

ASSEMBLY INSTRUCTION #3172-C



NO	DESCRIPTION	QTY
1	Top 	1 Pc
2A	Strecher A 	1 Pc
2B	Strecher B 	1 Pc
3	Leg 	4 Pcs



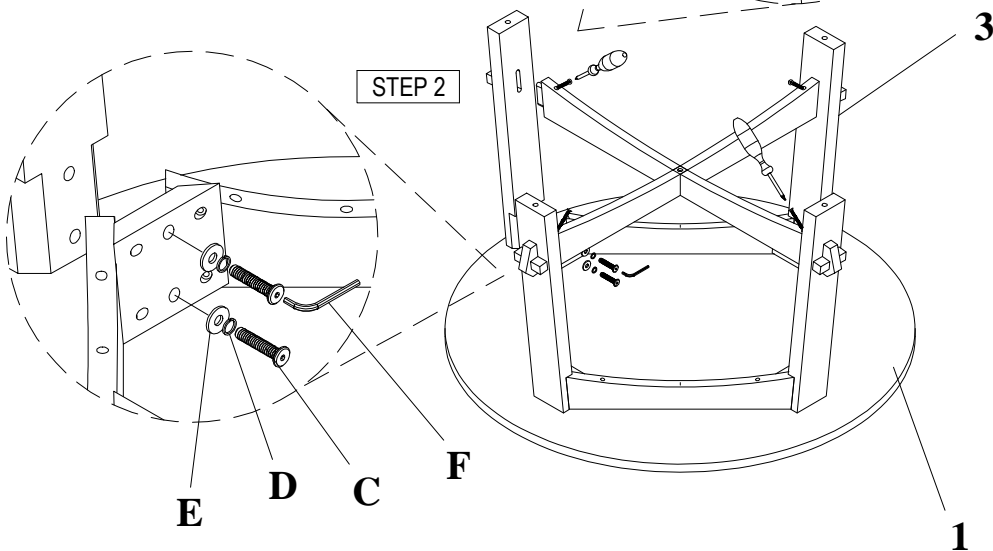
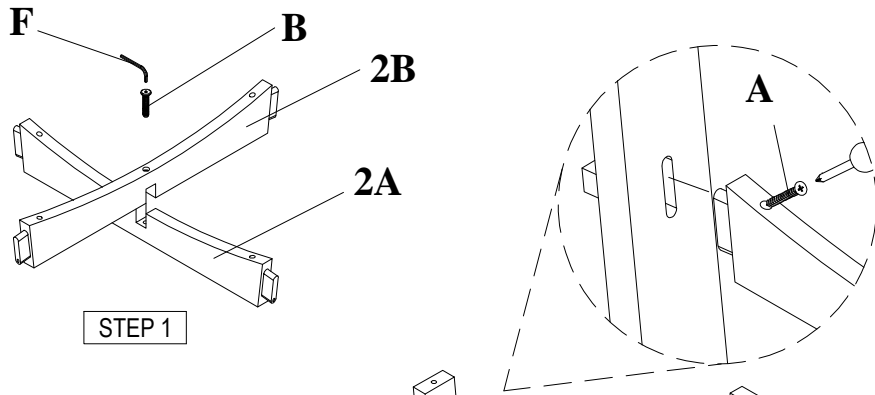

HARDWARE LIST

NO	SKETCH	HARDWARE	QTY
A		Screw Ø8 x 50	4 Pcs
B		JCBC M6 x 35	1 Pc
C		JCBC M8 x 50	8 Pcs
D		Spring Washer	8 Pcs
E		Plat Washer	8 Pcs
F		L key	1 Pc





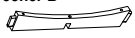



ASSEMBLY INSTRUCTION #3172-C



NO	DESCRIPTION	QTY
1	Top 	1 Pc
2A	Strecher A 	1 Pc
2B	Strecher B 	1 Pc
3	Leg 	4 Pcs

HARDWARE LIST

NO	SKETCH	HARDWARE	QTY
A		Screw Ø8 x 50	4 Pcs
B		JCBC M6 x 35	1 Pc
C		JCBC M8 x 50	8 Pcs
D		Spring Washer	8 Pcs
E		Plat Washer	8 Pcs
F		L key	1 Pc

