









ASSEMBLY INSTRUCTIONS #3131-C

HARDWARE LIST

NO	SKETCH	HARDWARE	QTY
1		JCBC M6 x 35mm	14 pcs
2		Plat Washer M6	14 pcs
3		Spring Washer M6	14 pcs
4		Allen Key	1 pc

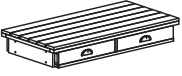
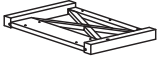
PART LIST

NO	DESCRIPTION	SKETCH	QTY
A	Body		1 pc
B	Left Side		1 pc
C	Right Side		1 pc
D	Bottom		1 pc

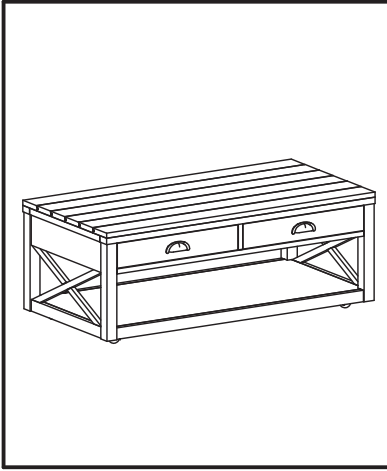

ASSEMBLY STEP

STEP 1

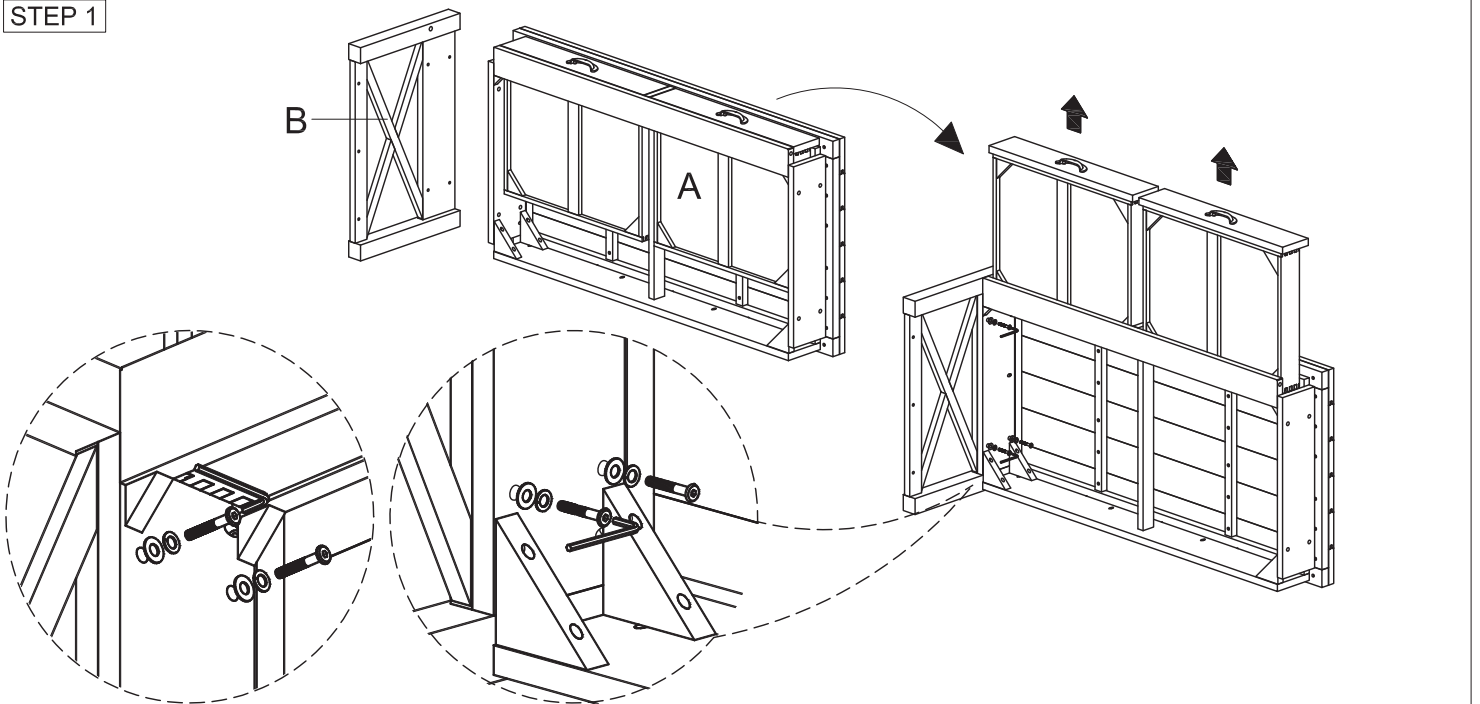

STEP 2

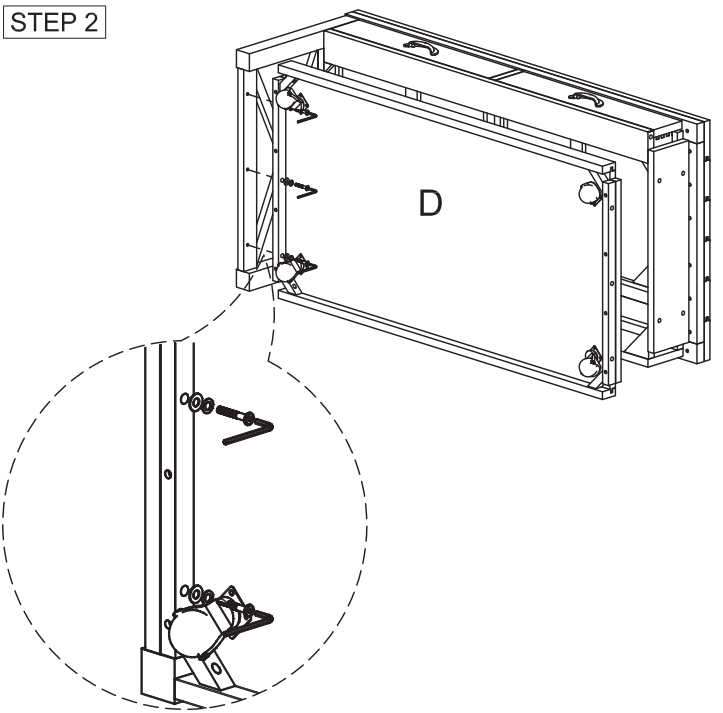

STEP 3

