





ASSEMBLED INSTRUCTIONS

INSTRUCCIONES

PARTS LIST

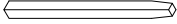
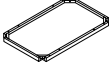
LISTA DE PARTES

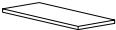
2620T-4062 Counter-height Table

1	Table Top		1PC/PIEZA
2	Leg		4PC/PIEZA
3	Bottom shelf		1PC/PIEZA
4	Left/Right panel		4PCS/PIEZAS
5	Middle panel		2PCS/PIEZAS
6	Shelf		2PCS/PIEZAS
7	X Left panel		1PC/PIEZA
8	X Right panel		1PC/PIEZA

A		BOLT $\phi 1/4 \times 1-3/4$ "	12PCS/PIEZAS
B		BOLT $\phi 5/16 \times 2$ "	12PCS/PIEZAS
C		ALLEN WRENCH 4mm	1PC/PIEZA
D		shelf support	8PCS/PIEZAS
E		Dowel $\phi 8 \times 30$ mm	16PCS/PIEZAS

ASSEMBLED INSTRUCTIONS

INSTRUCCIONES

STEP/PASO:1

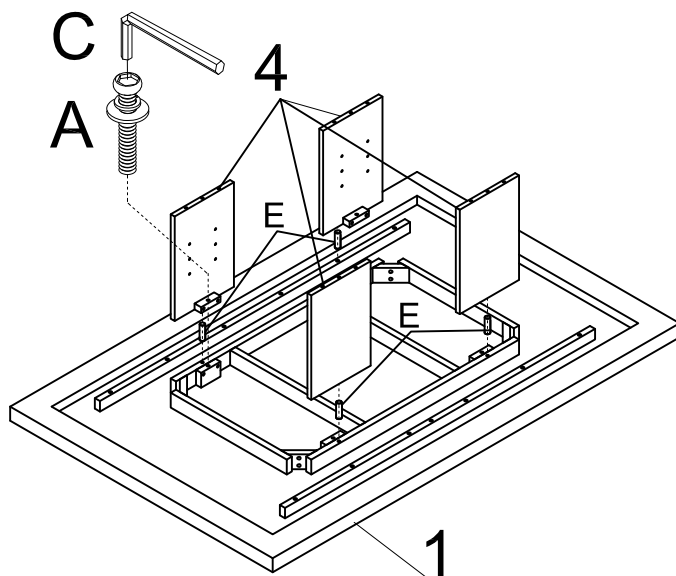

STEP/PASO:2

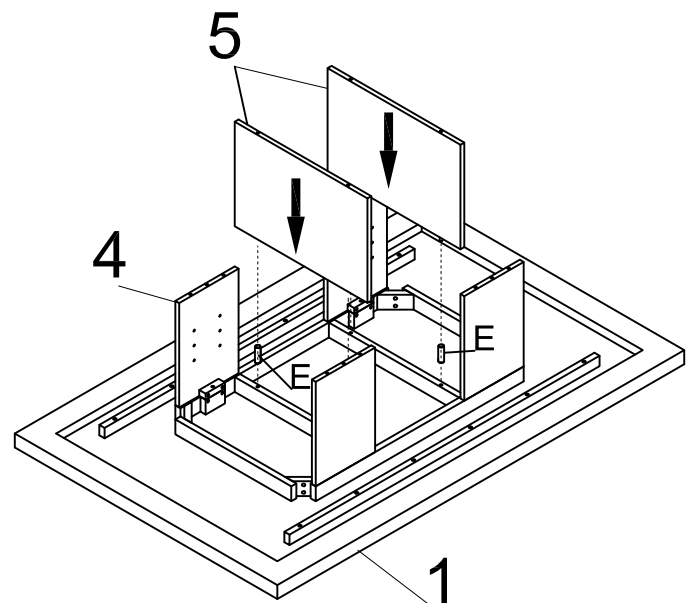

STEP/PASO:3

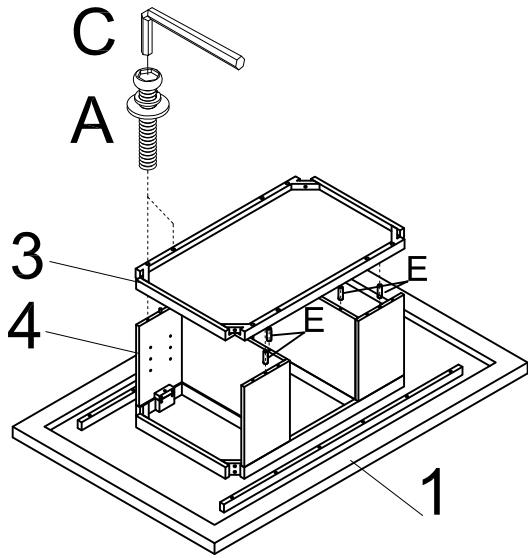

STEP/PASO:4

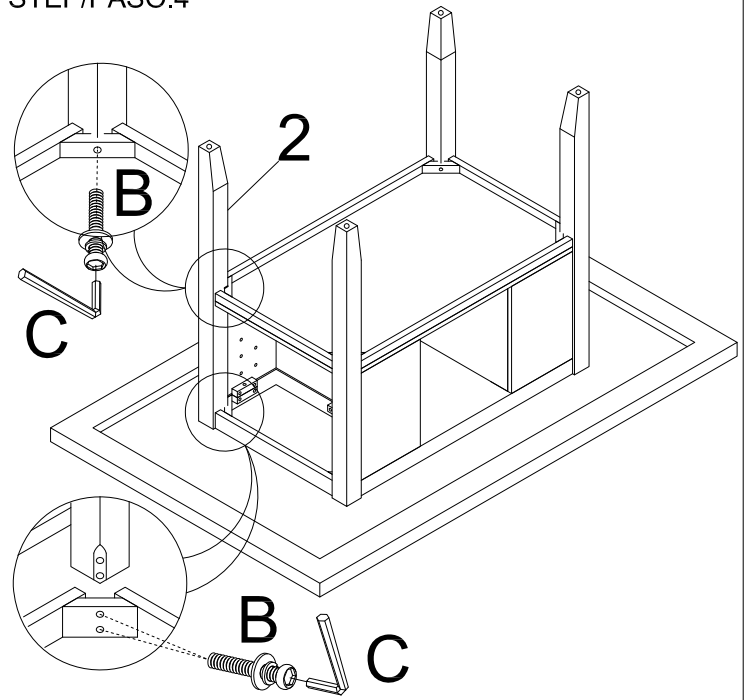

STEP/PASO:5

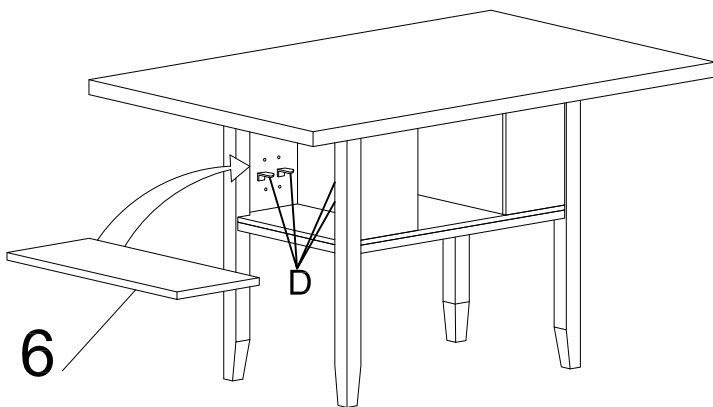

STEP/PASO:6

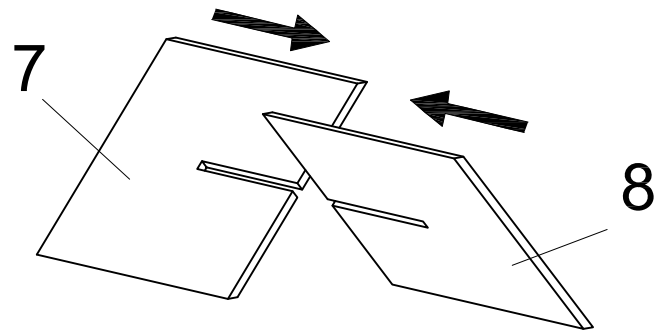

STEP/PASO:7

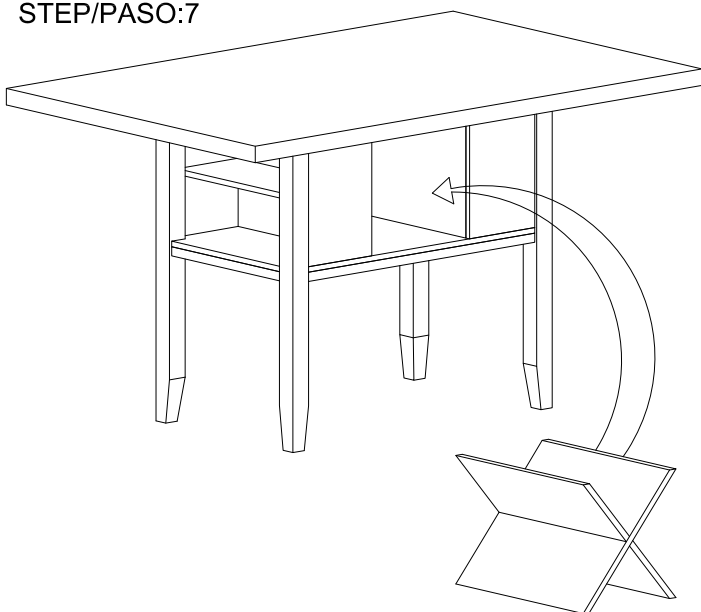

STEP/PASO:8

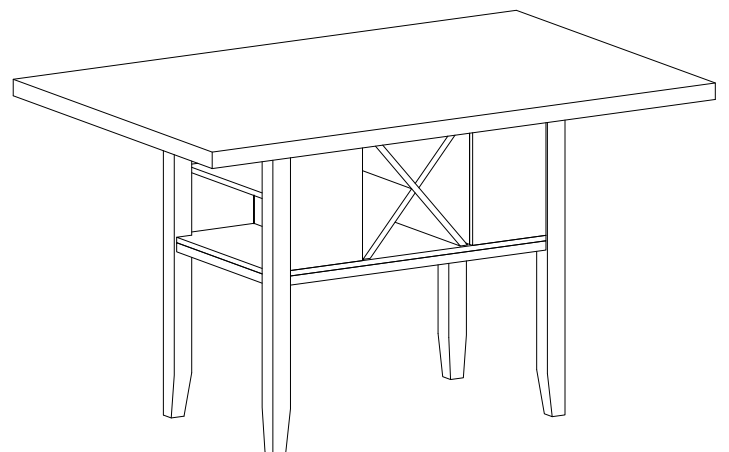

DO NOT TIGHTEN ALL BOLTS UNTIL COMPLETELY ASSEMBLED
NO APRETAR LOS TORNILLOS HASTA ARMAR COMPLETAMENTE