

ASSEMBLY INSTRUCTION

INSTRUCCIONES





2430SET-LG / 2430SET-P TABLE

2430SET-LG / 2430SET-P MESA

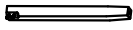
PARTS LIST

LISTA DE PARTES

A		1 PC/PIEZA
B		4 PCS/PIEZAS

①		OPEN WRENCH Ø12	1 PC/PIEZA
②		NUT Ø5/16"	8 PCS/PIEZAS
③		LOCK WASHER 5/16"*13mm	8 PCS/PIEZAS
④		FLAT WASHER 5/16"*19mm	8 PCS/PIEZAS

ASSEMBLY INSTRUCTION

INSTRUCCIONES

Step 1

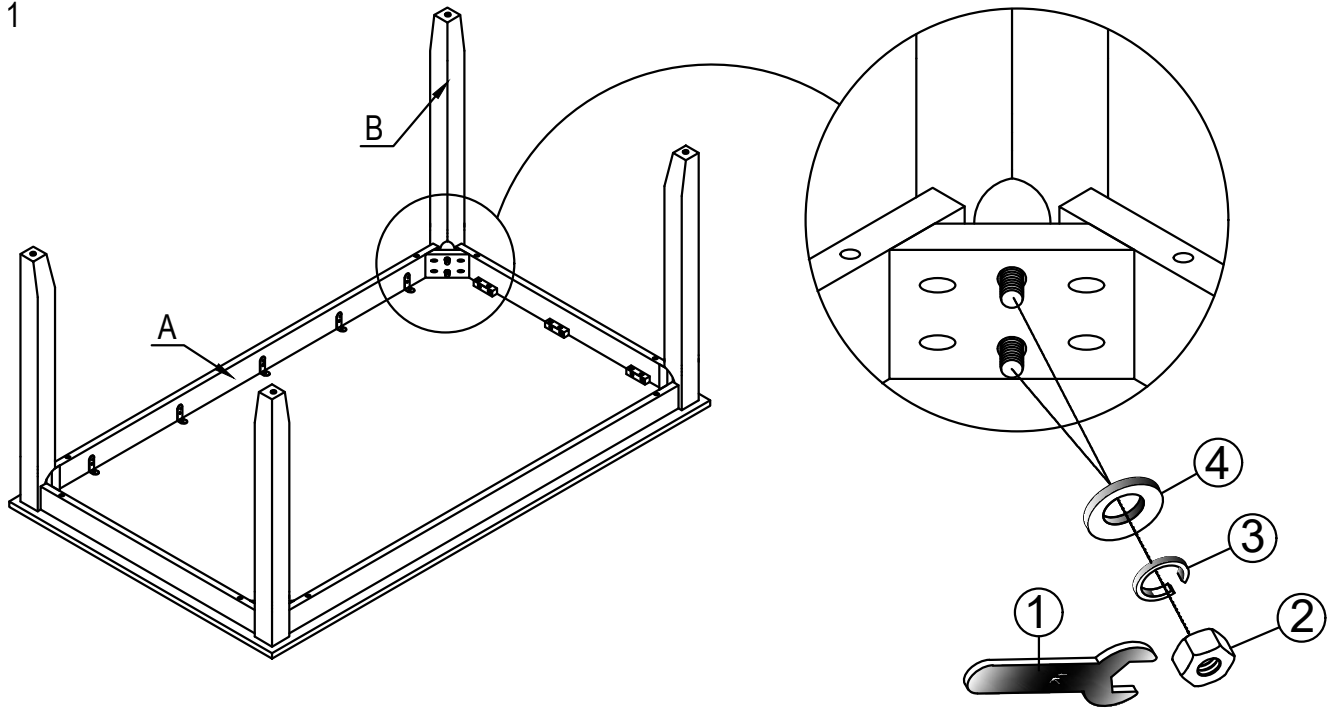

Step 2

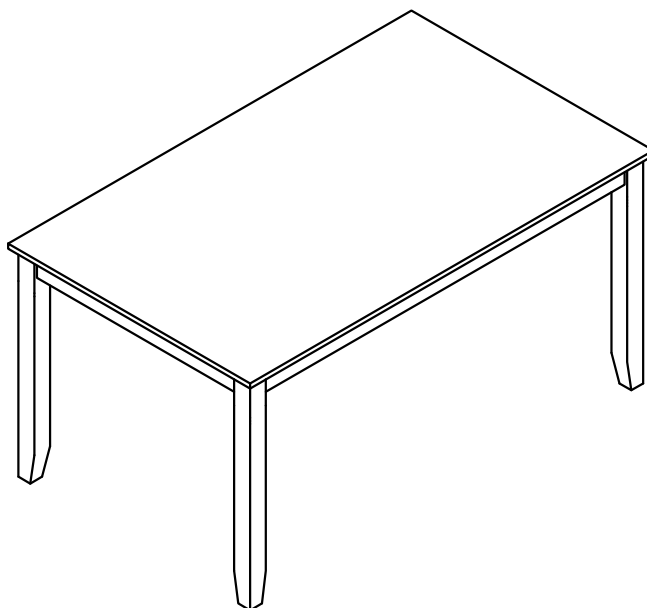







DO NOT TIGHTEN ALL BOLTS UNTIL COMPLETELY ASSEMBLED.
NO APRETERER LOS TORNILLOS HASTA ARMAR COMPLETAMENTE.

ASSEMBLY INSTRUCTION INSTRUCCIONES

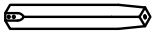
2430SET-LG / 2430SET-P- CHAIR 2430SET-LG / 2430SET-P- SILLA

PARTS LIST LISTA DE PARTES

C		1 PC/PIEZA
D		1 PC/PIEZA
E		2 PCS/PIEZAS

⑤		BOLT 1/4''*20*3-1/8" (chair back leg corner)	4 PCS/PIEZAS
⑥		BOLT 1/4''*20*2-5/8" (front leg)	4 PCS/PIEZAS
⑦		BOLT 1/4''*20*1-1/2" (chair back center)	1 PC/PIEZA
⑧		ALLEN KEY Ø1/4*2-1/4"	1 PC/PIEZA

ASSEMBLY INSTRUCTION INSTRUCCIONES

Step 1

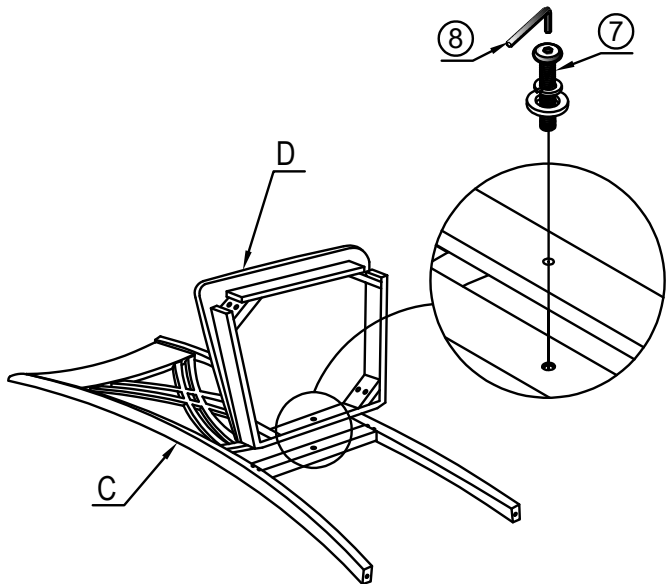

Step 2

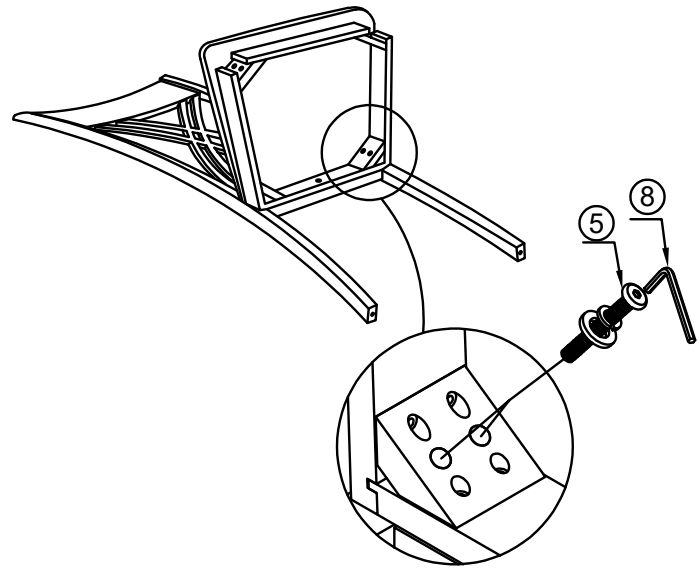

Step 3

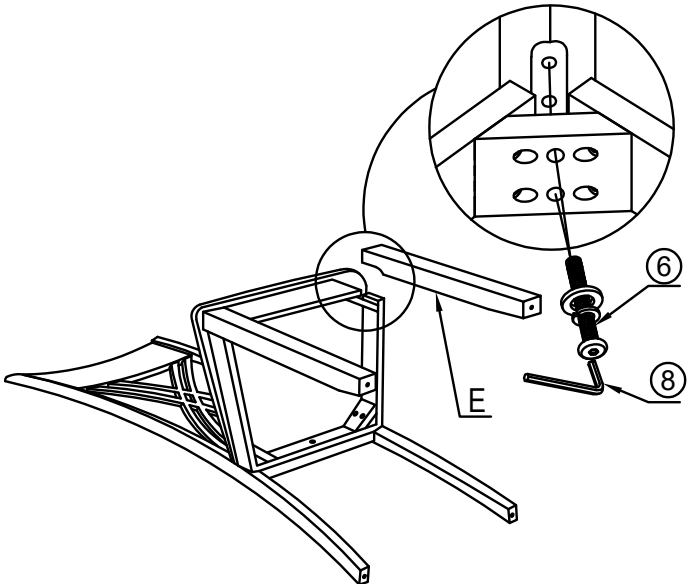

Step 4

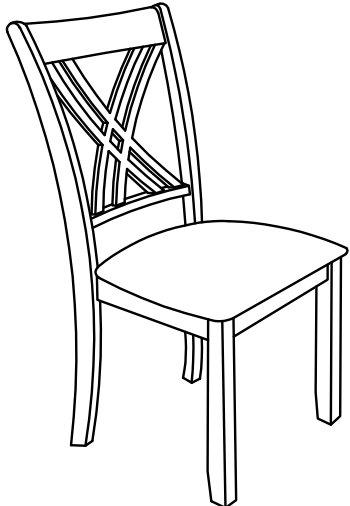

DO NOT TIGHTEN ALL BOLTS UNTIL COMPLETELY ASSEMBLED.
NO APRETER LOS TORNILLOS HASTA ARMAR COMPLETAMENTE.