

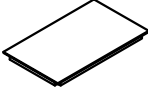





ASSEMBLY INSTRUCTION 2325SET/2325SET-GY/2325SET-LG TABLE INSTRUCCIONES 2325SET/2325SET-GY/2325SET-LG MESA



No	DESCRIPTION		Q'TY
A	TABLE TOP		1 pc/pieza
B	TABLE LEG		4 pcs/piezas
①	OPEN WRENCH	 Ø12	1 pc/pieza
②	NUT	 Ø5/16"	8 pcs/piezas
③	SPRING WASHER	 Ø5/16"*13mm	8 pcs/piezas
④	METAL WASHER	 Ø5/16"*19mm	8 pcs/piezas



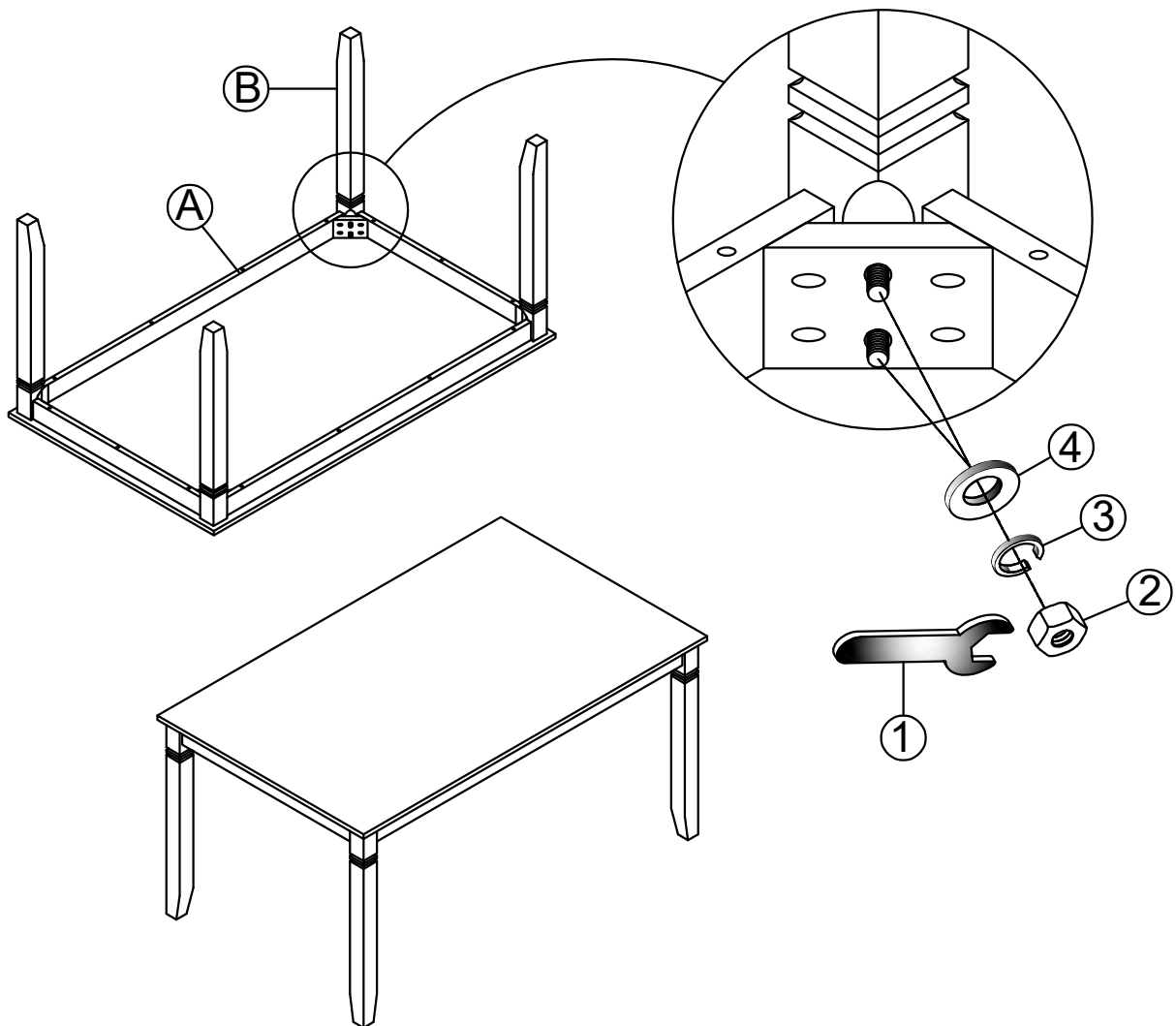





DO NOT TIGHTEN ALL BOLT UNTIL COMPLETELY ASSEMBLED.
NO APRETER LOS TORNILLOS HASTA ARMAR COMPLETAMENTE.

ASSEMBLY INSTRUCTION 2325SET/2325SET-GY/2325SET-LG CHAIR

INSTRUCCIONES 2325SET/2325SET-GY/2325SET-LG SILLA

No	DESCRIPTION	Q'TY
C	CHAIR BACK 	1 pc/pieza
D	SEAT FRAME & CUSHION 	1 pc/pieza
E	LEG 	2 pcs/piezas

No	DESCRIPTION	Q'TY
⑤	SPRING WASHER  Ø5/16*11mm	4 pcs/piezas
⑥	METAL WASHER  Ø5/16*19mm	4 pcs/piezas
⑦	BOLT  Ø1/4"*20*1-1/2" (chair back center)	3 pcs/piezas
⑧	NUT  Ø5/16" (front leg)	4 pcs/piezas
⑨	BOLT  Ø1/4"*20*3-1/8" (chair back leg corner)	4 pcs/piezas
⑩	OPEN WRENCH  Ø12	1 pc/pieza
⑪	ALLEN KEY  Ø1/4*2-1/4"	1 pc/pieza

Step 1/ paso 1

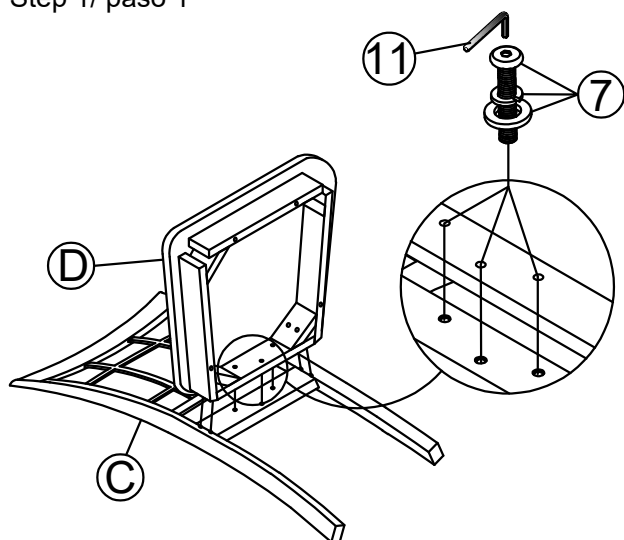

Step 2/ paso 2

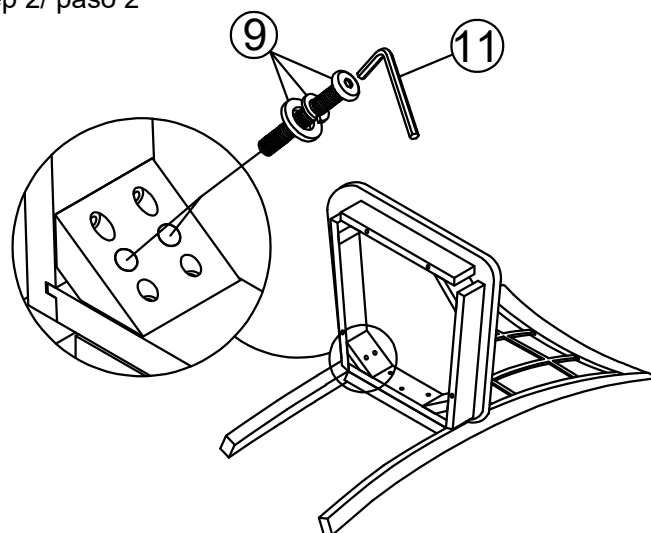

Step 3/ paso 3

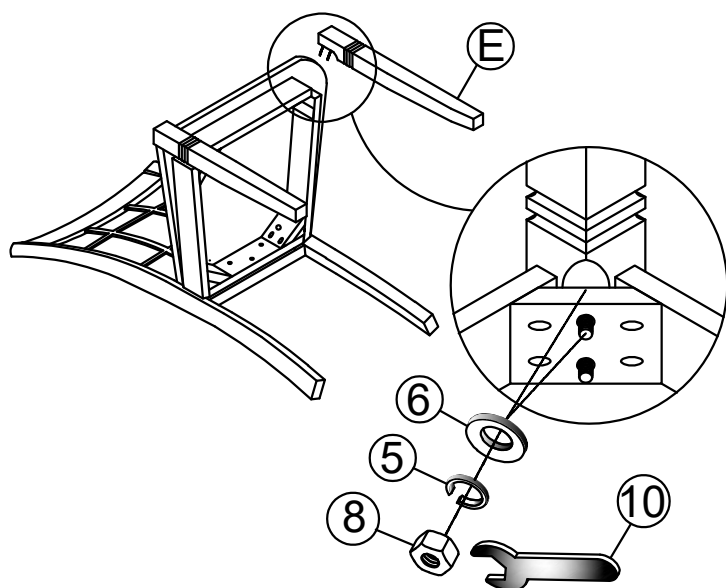

Step 4/ paso 4

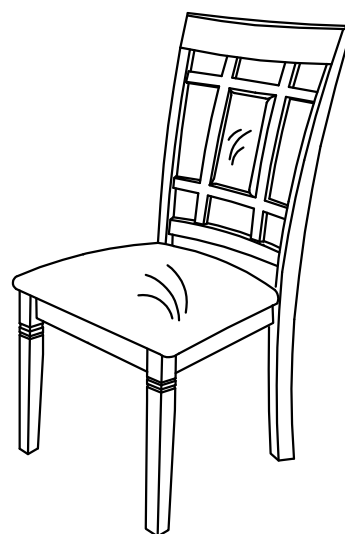



DO NOT TIGHTEN ALL BOLT UNTIL COMPLETELY ASSEMBLED.
NO APRETER LOS TORNILLOS HASTA ARMAR COMPLETAMENTE.

ASSEMBLY INSTRUCTION
INSTRUCCIONES

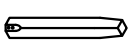
2325SET-GY/2325SET-LG BENCH
2325SET-GY/2325SET-LG BANCA

No	DESCRIPTION	Q'TY
F	SEAT 	1 pc/pieza
G	LEG 	4 pcs/piezas

No	DESCRIPTION	Q'TY
13	BOLT  1/4"*20*2-1/2"	8 pcs/piezas
14	ALLEN KEY  Ø1/4*2-1/4"	1 pc/pieza

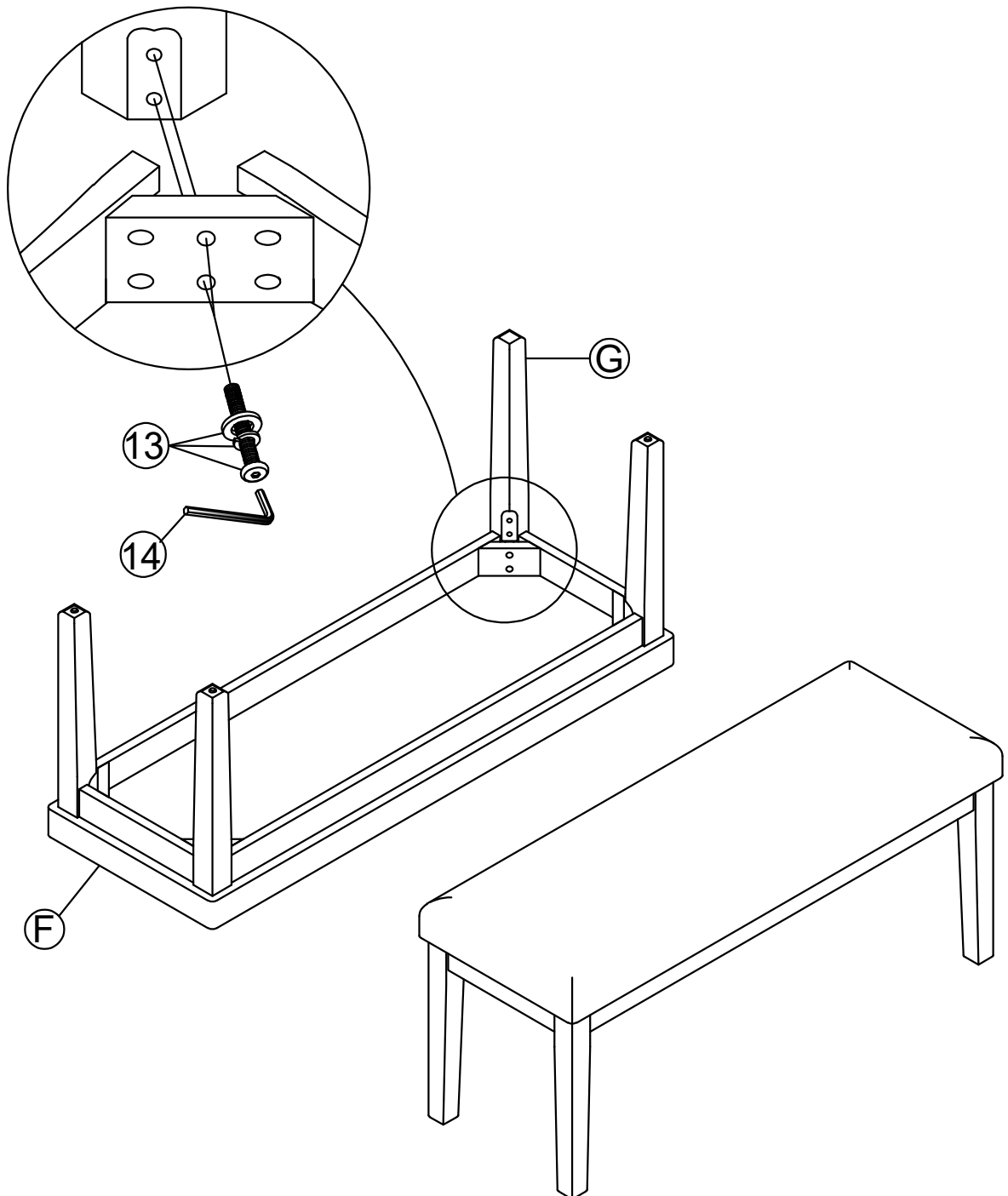

DO NOT TIGHTEN ALL BOLT UNTIL COMPLETELY ASSEMBLED.
NO APRETER LOS TORNILLOS HASTA ARMAR COMPLETAMENTE.