



ASSEMBLY INSTRUCTIONS #2320-QR

HARDWARE LIST

NO	SKETCH	HARDWARE	QTY
6		Bolt M8 x 80mm	8 pcs
7		Hexagonal Nut M8	8 pcs
8		Curve Ring	8 pcs
9		Screw Ø8 x 1 1/4"	8 pcs
10		Wrench Key	1 pc

PART LIST

NO	DESCRIPTION	SKETCH	QTY
E	Ass. Headboard		1 pc
F	Ass. Footboard		1 pc
G	Side Rail		2 pcs
H	Slat Matras		4 pcs
I	Leg Center Matras		4 pcs
J	Leg Footboard		2 pcs

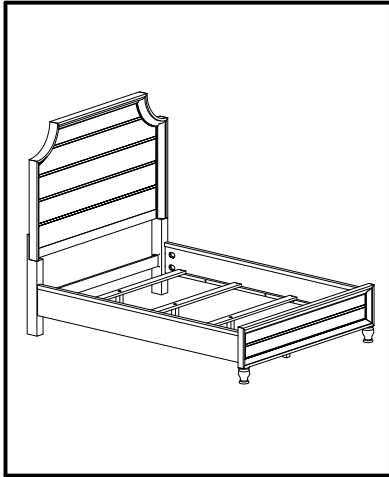

ASSEMBLY STEP

BEFORE YOU START ASSEMBLING, PLEASE MAKE SURE ALL PARTS & HARDWARE ARE INCLUDED IN BOX

STEP 1

Assembly leg footboard

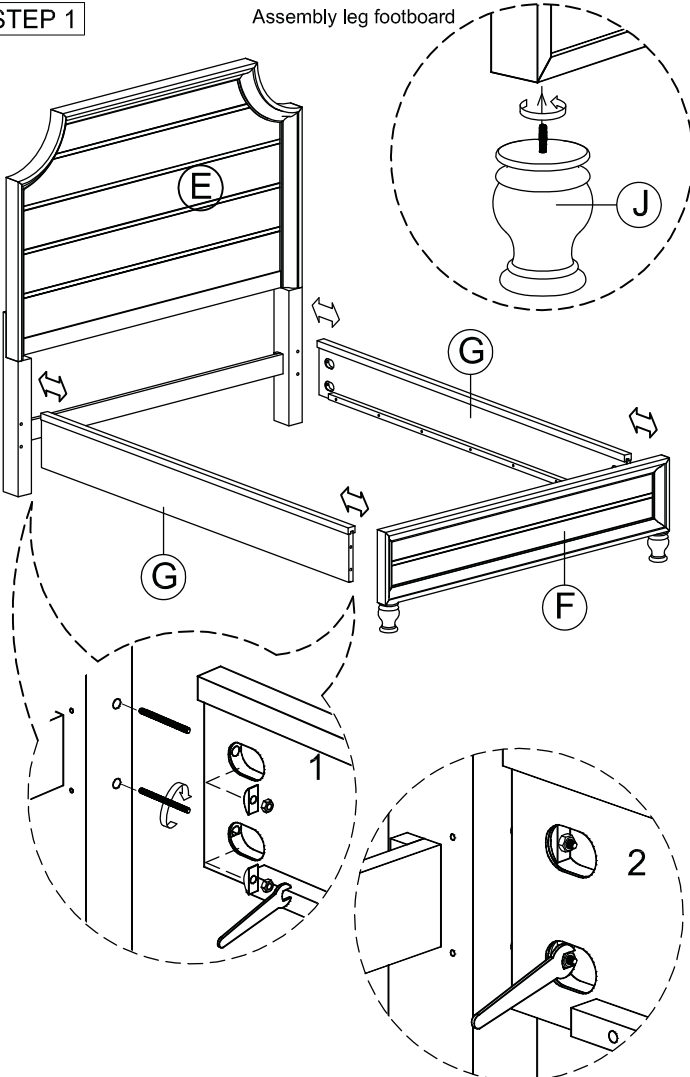

STEP 2

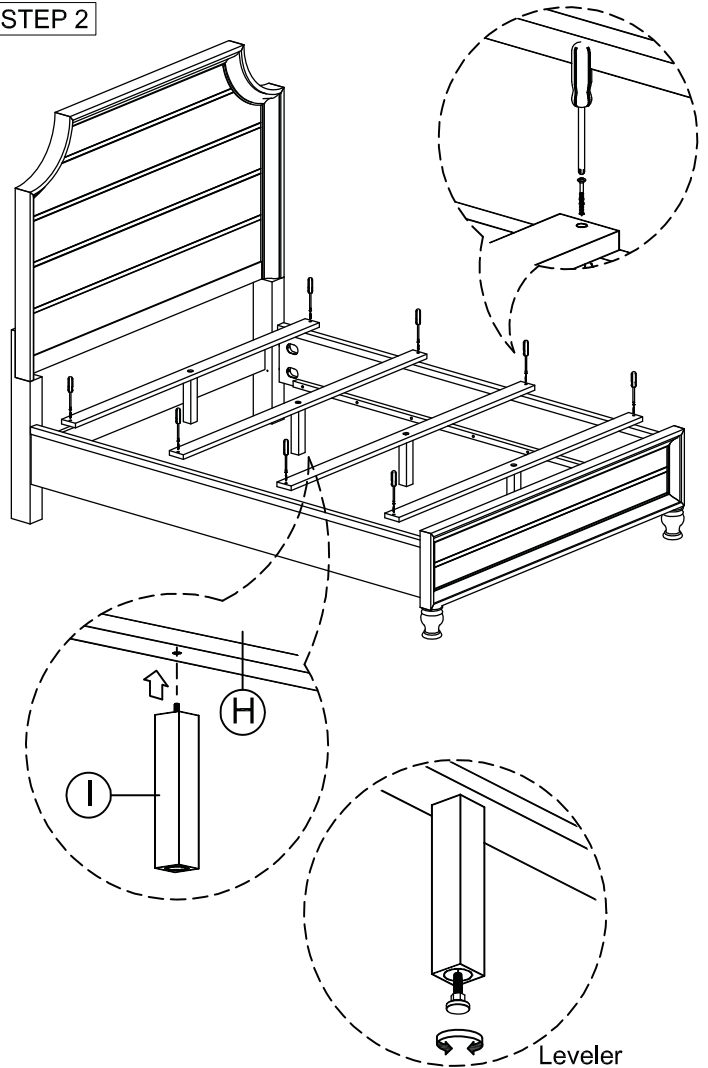

WARNING : Do not tighten up the bolt in one side for this step, until all bolt and part is properly assembled.