



ASSEMBLY INSTRUCTION INSTRUCCIONES



2270CLT-4286 (DINING TABLE)

2270CLT-4286 (MESA DE COMEDOR)

BOX 1

HARDWARE LIST / LISTA DE TORNILLO			
A		BOLT (Ø5/16" x 18 x 1-1/2")	24PCS
B		BOLT (Ø5/16" x 18 x 4")	6PCS
C		FLAT WASHER Ø5/16"	6PCS
D		LOCK WASHER Ø5/16"	6PCS
E		LOCK NUT (12mm)	6PCS
F		CURVE WASHER	6PCS
G		WRENCH (12mm)	1PC
H		ALLEN KEY (4mm)	1PC

BOX 1 TABLE TOP

PARTS LIST / LISTA DE PARTES			
1		TABLE TOP	1PC
2		LONG STRETCHER	1PC
3		BASE CONNECT BOARD	2PCS

BOX 2 TABLE BASE

4		TABLE LEG	4PCS
5		SHORT STRETCHER	2PCS

THE HARDWARE IS LOCATED IN THE PACKING ITEMS

STEP 1

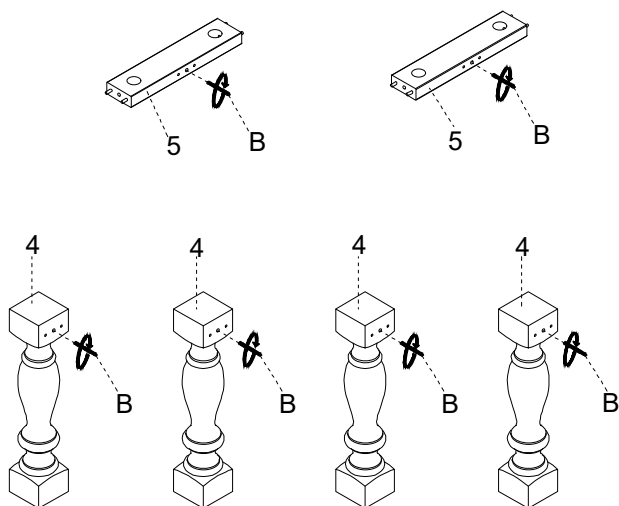

STEP 2

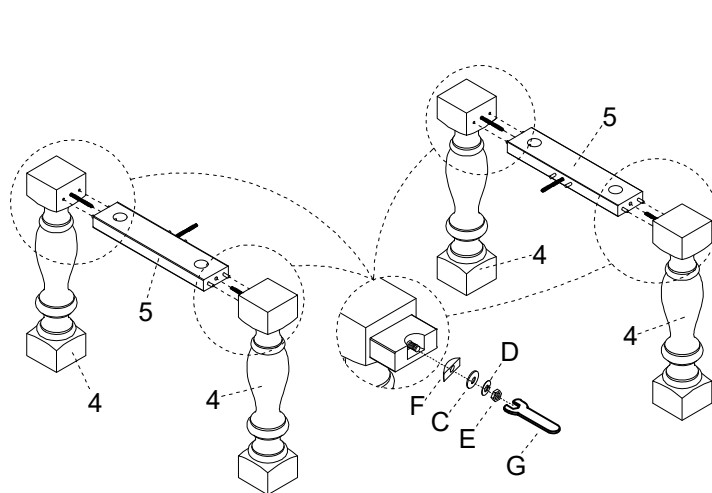

STEP 3

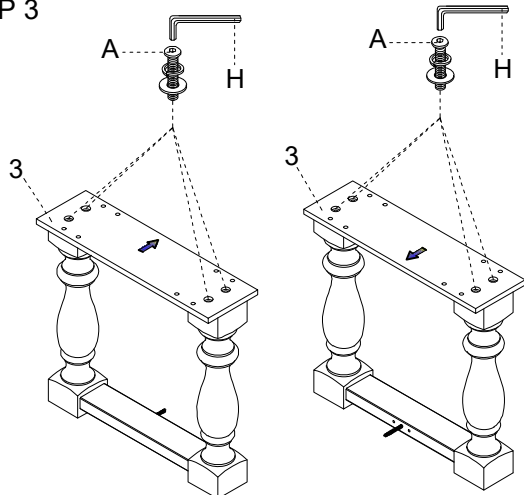

STEP 4

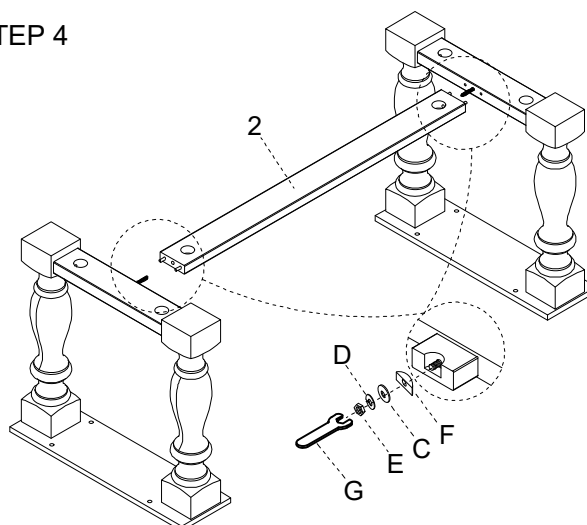

**DO NOT TIGHTEN ALL BOLTS UNTIL COMPLETELY ASSEMBLED !
NO APRETER LOS TORNILLOS HASTA ARMAR COMPLETAMENTE**

ASSEMBLY INSTRUCTION INSTRUCCIONES

2270CLT-4286 (DINING TABLE)

2270CLT-4286 (MESA DE COMEDOR)

STEP 5

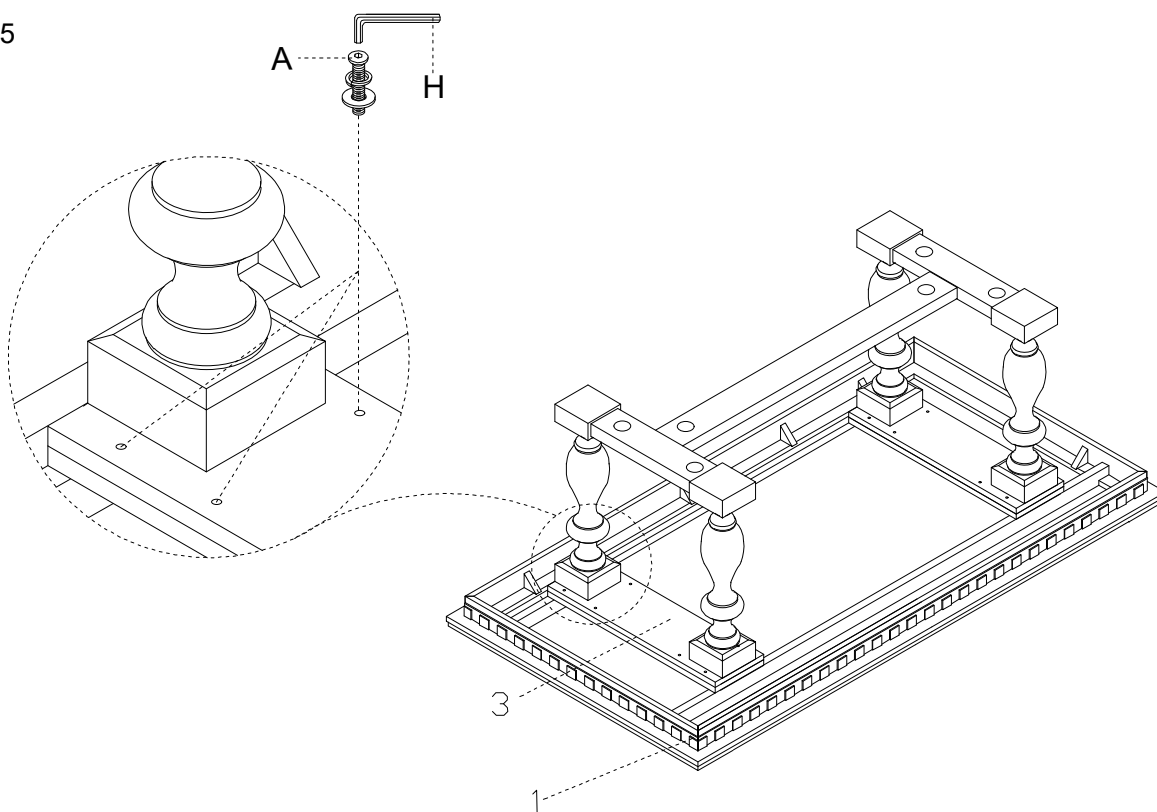

FINISH

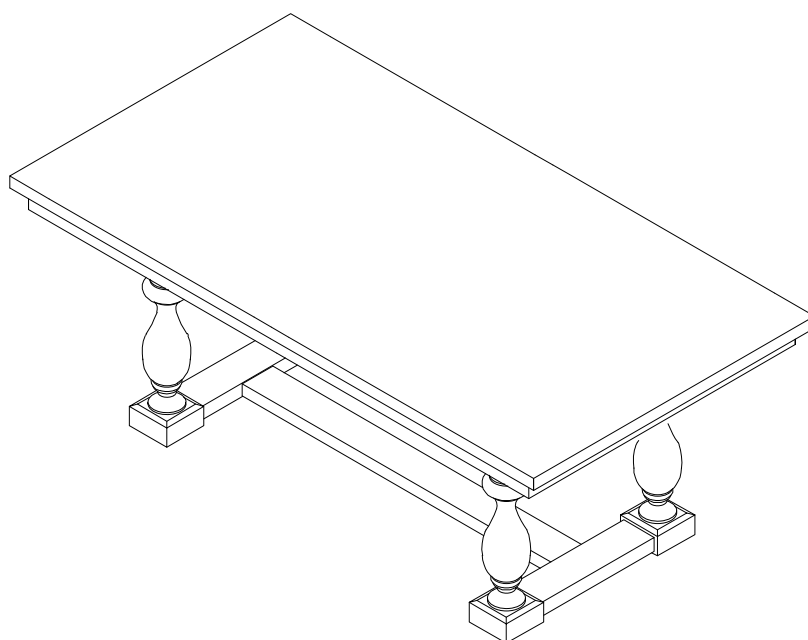

**DO NOT TIGHTEN ALL BOLTS UNTIL COMPLETELY ASSEMBLED !
NO APRETER LOS TORNILLOS HASTA ARMAR COMPLETAMENTE**