







# ASSEMBLY INSTRUCTION

## JUDSON 5- PK COUNTER TABLE SET

### 1717SET-GT

PARTS LIST		
No.	PART	Q'TY
A	SEAT FRAME WITH CUSHION	4
B	BACK FRAME WITH CUSHION	4
C	FRONT LEFT LEG	4
D	FRONT RIGHT LEG	4
E	FRONT STRETCHER	4
F	LEFT STRETCHER	4
G	RIGHT STRETCHER	4

HARDWARE LIST			
NO.	PART	DESCRIPTION	Q'TY
1		ALLEN BOLT (5/16" x 83mm)	16
2		ALLEN BOLT (5/16" x 57mm)	16
3		ALLEN BOLT (5/16" x 45mm)	8
4		SCREW (35mm)	24
5		SPRING WASHER (5/16" x 13mm)	40
6		FLAT WASHER (5/16" x 19mm)	40
7		ALLEN KEY M5x 65mm	4

**TOOLS REQUIRED ( NOT PROVIDED)**

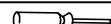
 Phillips Screw Driver

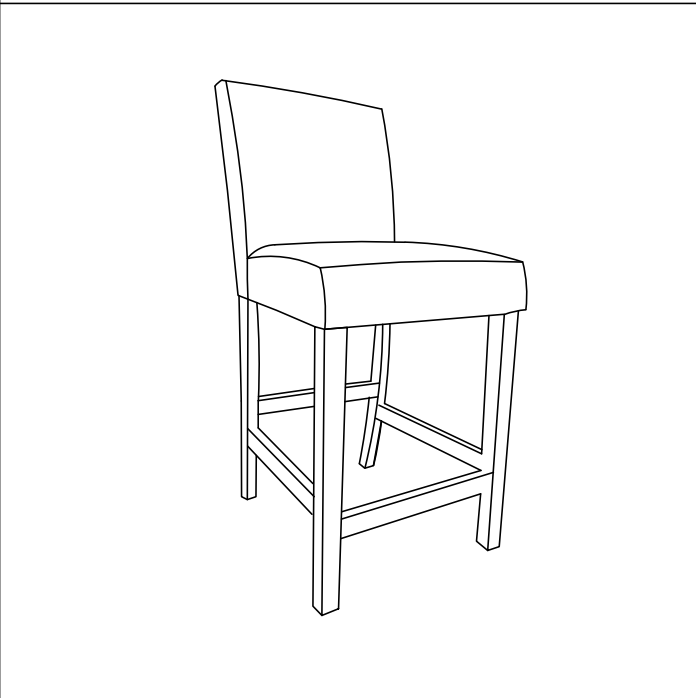
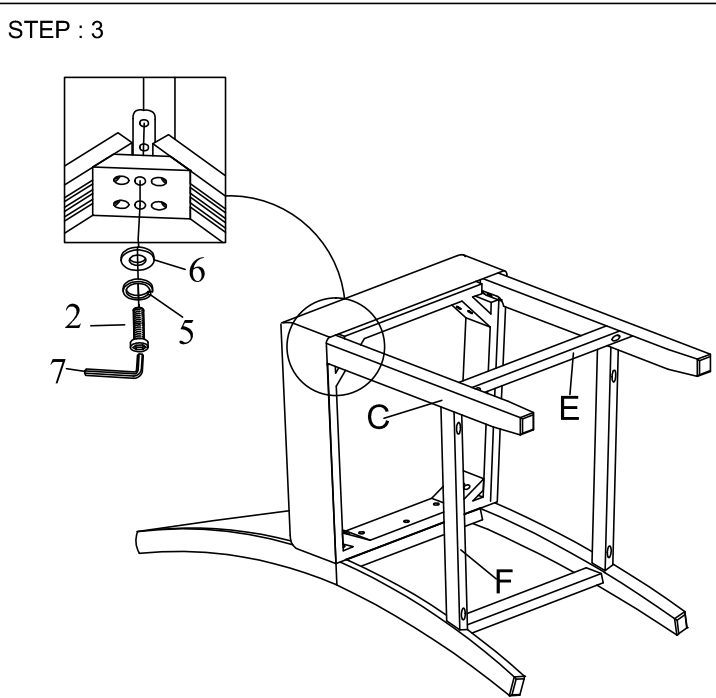
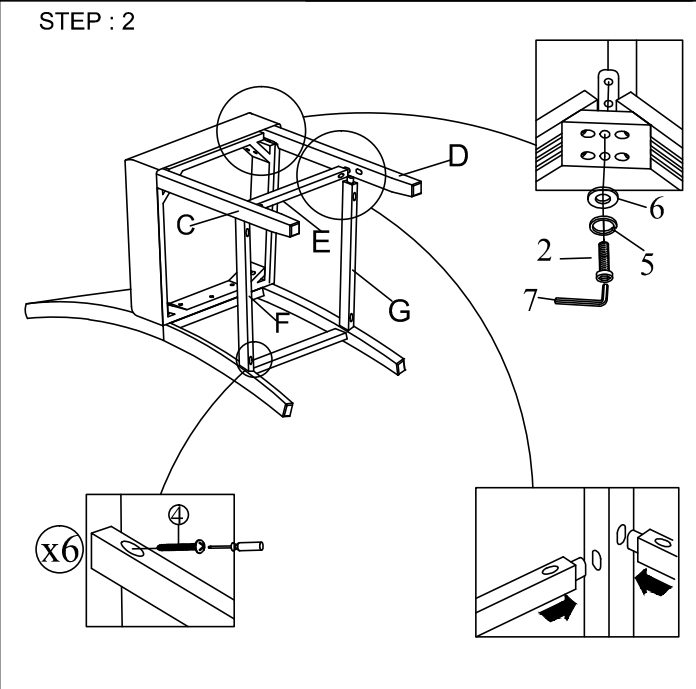
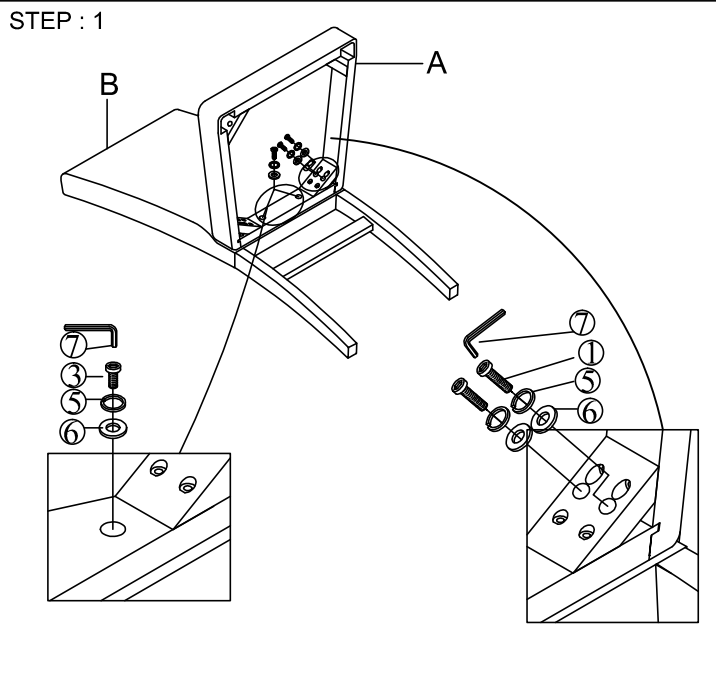

Note: Do not fully tighten any bolts until last step

# ASSEMBLY INSTRUCTION

## JUDSON 5- PK COUNTER TABLE SET

### 1717SET-GT

PART LIST		
No.	PART	Q'TY
A	TABLE TOP	1
B	TABLE LEG	4
C	TOP STRETCHER	1
D	BOTTOM STRETCHER	1

HARDWARE LIST			
NO.	DESCRIPTION	TABLE	Q'TY
1	ALLEN BOLT (5/16" x 57mm)		1
2	ALLEN BOLT (5/16" x 20mm)		8
3	SCREW 50mm		4
4	SCREW 20mm		8
5	SPRING WASHER (5/16" x 13mm)		9
6	FLAT WASHER (5/16" x 19mm)		9
7	ALLEN KEY M5x 65mm		1
8	CONNECTION TOOL 100x100x2.5mm		1
9	GLUE	1	

TOOLS REQUIRED ( NOT PROVIDED)

Phillips Screw Driver

#### STEP : 1

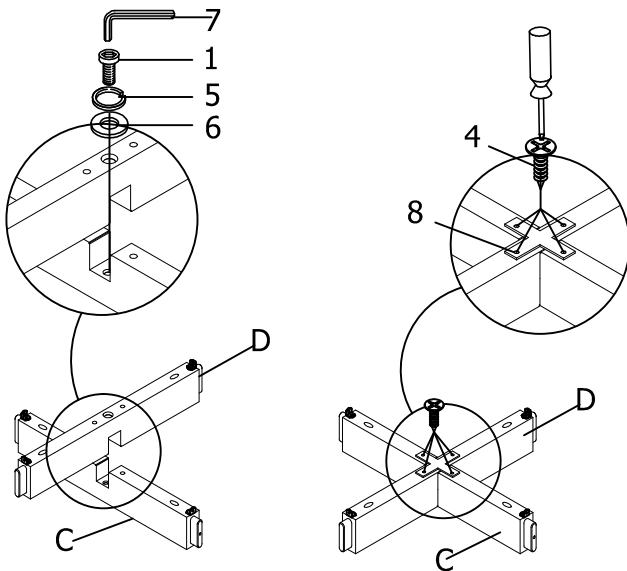

#### STEP : 2

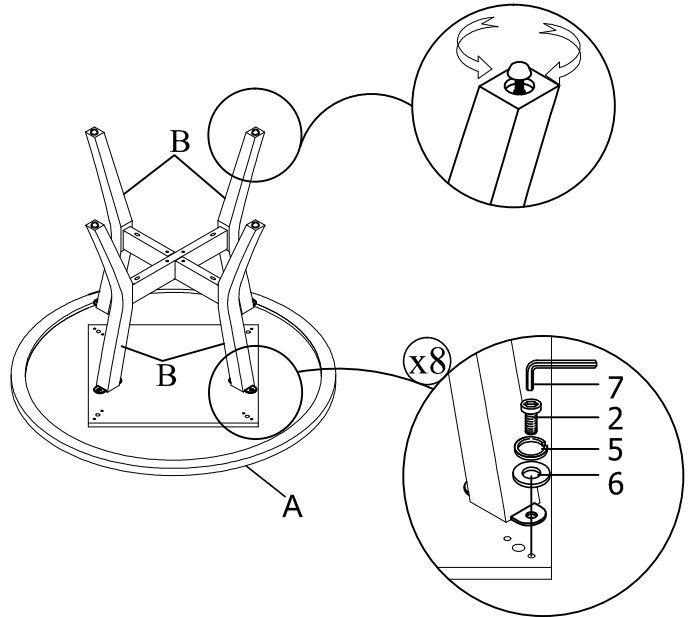

#### STEP : 3

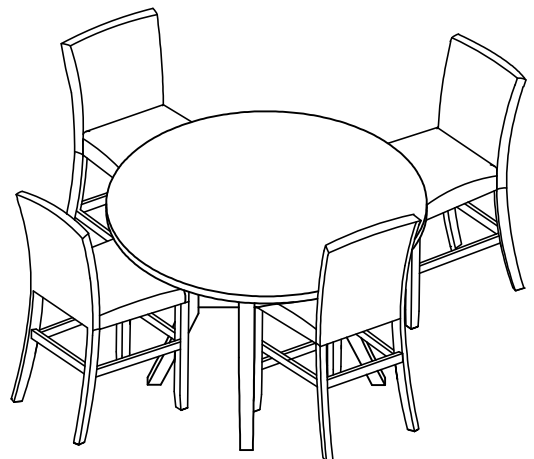
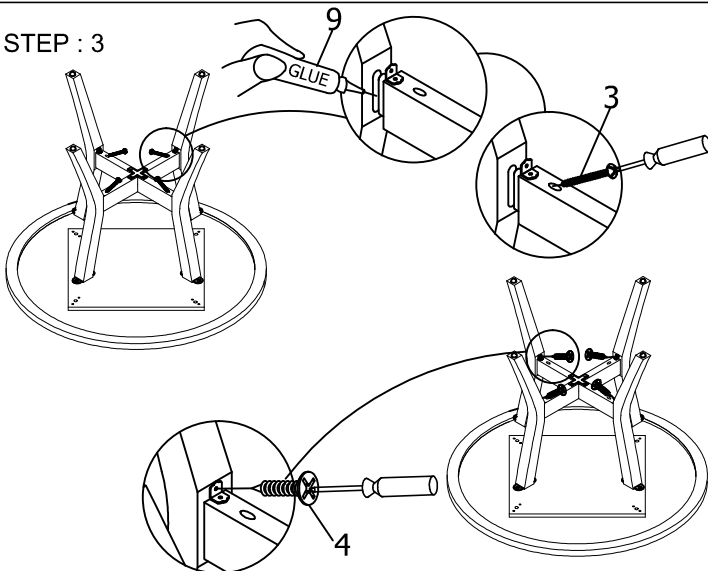

Note: Do not fully tighten any bolts until last step