



ASSEMBLY INSTRUCTION #1225

HARDWARE LIST

NO	HARDWARE	QTY
1	HEX BOLT M8 x 180mm	8 pcs
2	Hexagonal Nut	12 pcs
3	Spring Washer	12 pcs
4	Flat Washer	14 pcs
5	Wrench Key	1 pc
6	Allen Key	1 pc
7	JCBC M8 x 180mm	2 pcs

PART LIST

NO	SKETCH	QTY
A	TOP	1 pc
B	LEG	4 pcs
C	SUPPORT LEG	4 pcs
D	SHELF	1 pc

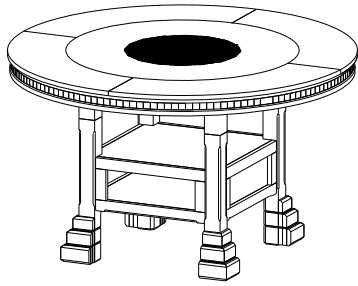

ASSEMBLY STEP

STEP 1

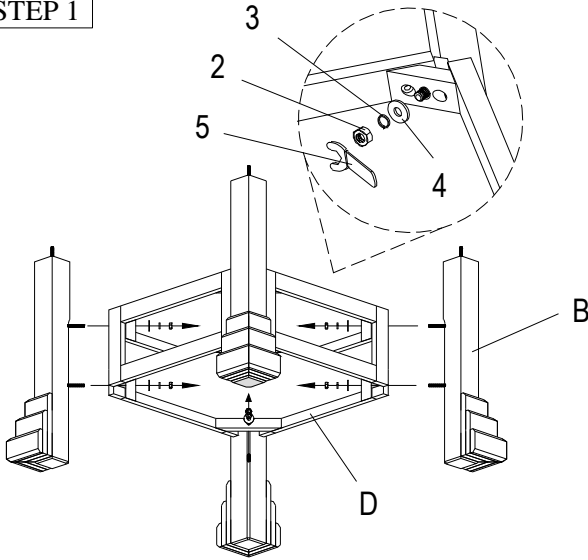

STEP 2

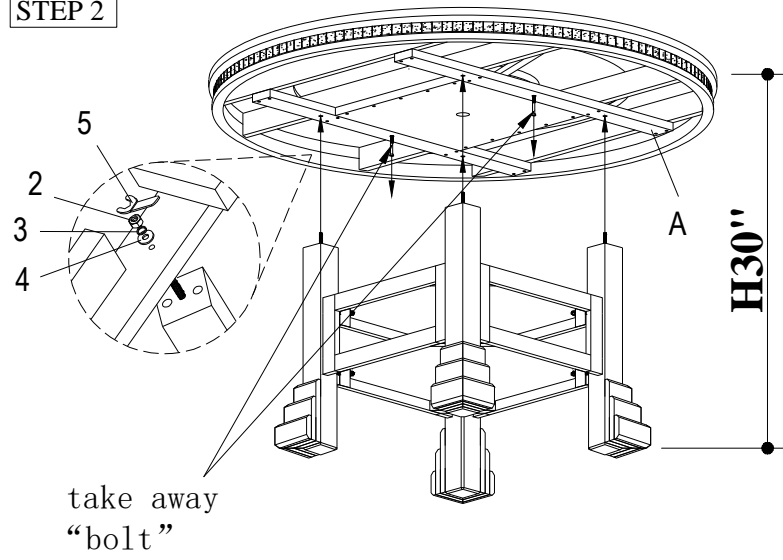

STEP 2

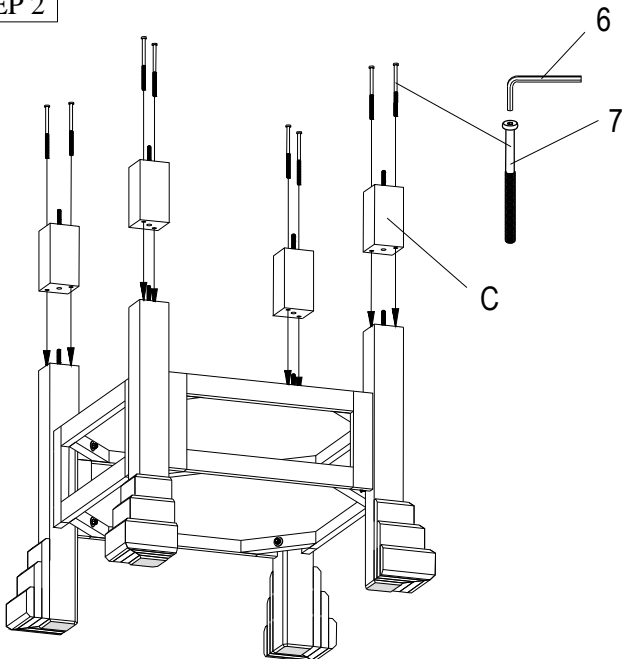

STEP 3

