



# ASSEMBLY INSTRUCTIONS #1167

## HARDWARE LIST

NO	SKETCH	HARDWARE	QTY
1		JCBC M8 x 50mm	8 Pcs
2		Spring Washer M8	8 Pcs
3		Flat Washer M8	8 Pcs
4		Hexagonal Nut M8	2 Pcs
5		Halfmoon Washer	2 Pcs
6		Bolt M8 x 80mm	2 Pcs
7		JCBC M6 x 20mm	4 Pcs
8		Wrench Key	1 Pc
9		Allen Key	1 Pc

## PART LIST

NO	DESCRIPTION	SKETCH	QTY
A	Top		1 Pc
B	Metal		2 Pcs
C	Leg		2 Pcs
D	Stretcher		1 Pc

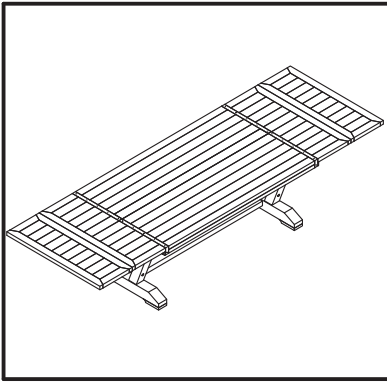

## ASSEMBLY STEP

### STEP 1

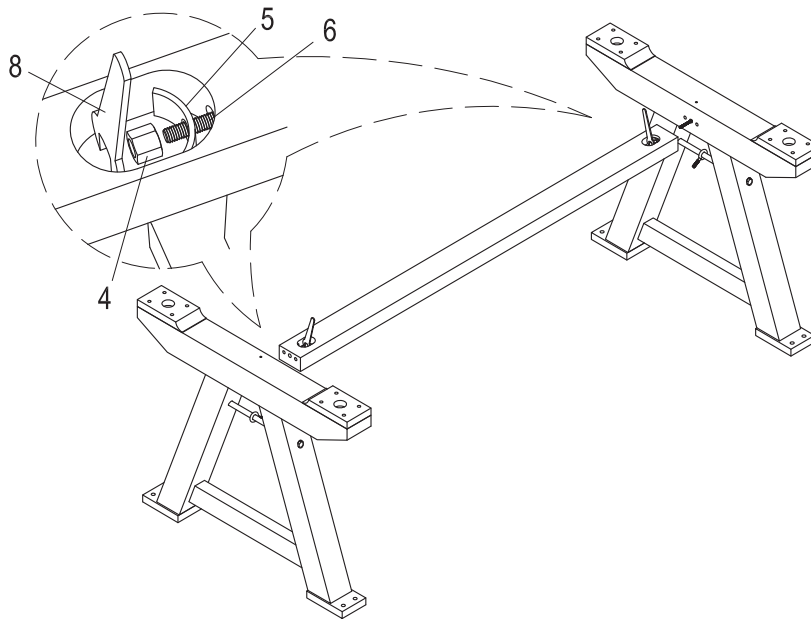

### STEP 2

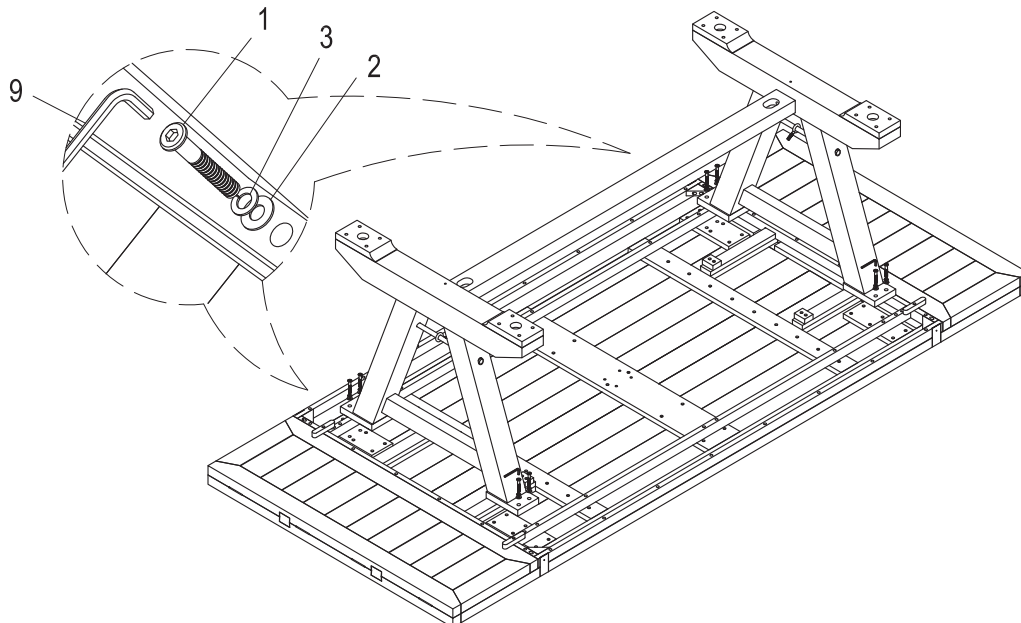

STEP 3

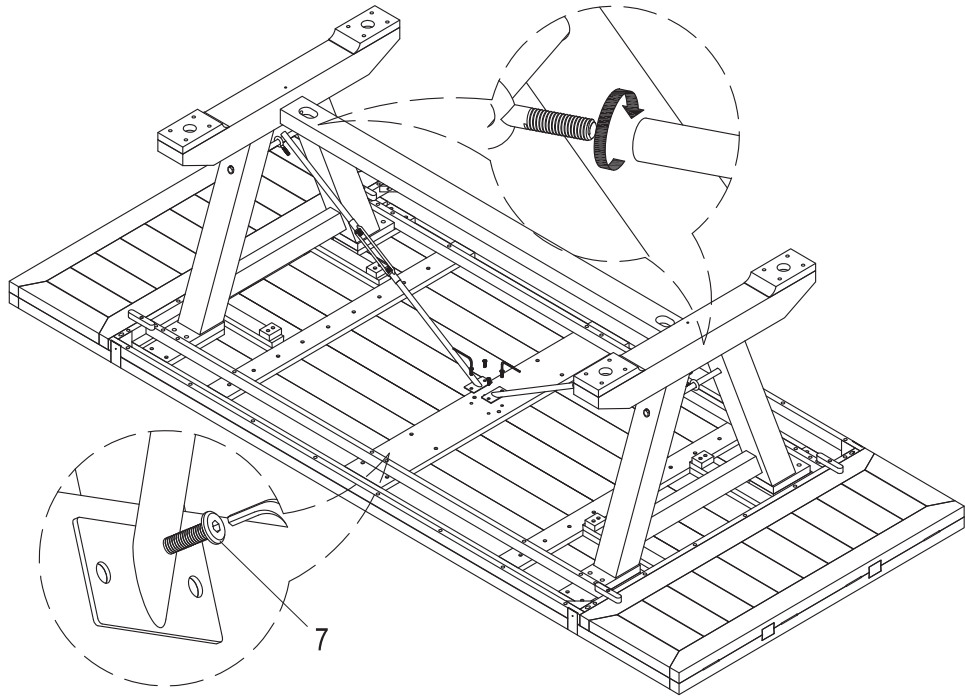

STEP 4

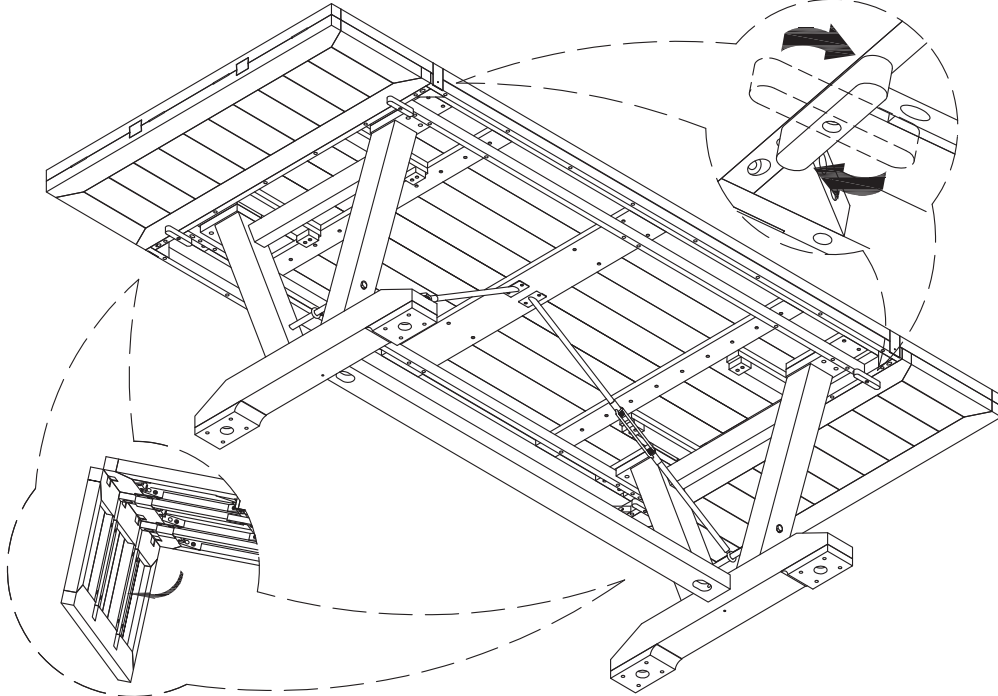

STEP 5

