



ASSEMBLY INSTRUCTION #1163

HARDWARE LIST

NO	SKETCH	HARDWARE	QTY
1		JCBC M6 x 20	24 pcs
2		JCBC M8 x 40	2 pcs
3		JCBC M8 x 60	4 pc
4		JCBC M8 x 100	2 pcs
5		Flat Washer M8	8 pc
6		Allen Key L4	1 pcs

PART LIST

NO	DESCRIPTION	SKETCH	QTY
A	Top		1 pc
B	Legs		2 pcs
C	Middle Stretcher		1 pc
D	Bottom Stretcher		1 pc
E	Stretcher Plug		2 pcs
F	Support Foot Rest		6 pcs
G	Foot Rest		1 pc

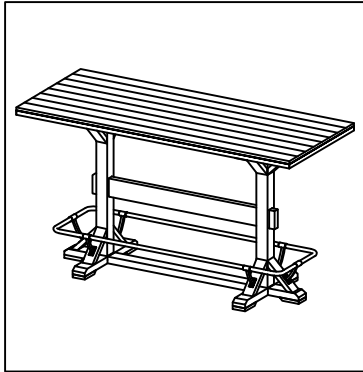

ASSEMBLY STEP

