

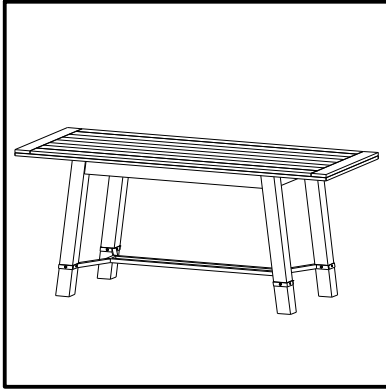

ASSEMBLY INSTRUCTION #1131



HARDWARE LIST

NO	SKETCH	HARDWARE	QTY
1		JCBC M6 x 20mm	8 pcs
2		JCBC M8 x 50mm	8 pcs
3		Spring Washer M8	8 pcs
4		Flat Washer	8 pcs
5		Allen Key	1 pc

PART LIST

NO	DESCRIPTION	SKETCH	QTY
A	Leg A		2 pcs
B	Leg B		2 pcs
C	Stretcher		1 pc
D	Top		1 pc

ASSEMBLY STEP

